

PART –A (PHYSICS)

1. If 10^{22} gas molecules each of mass 10^{-26} kg collide with a surface (perpendicular to it) elastically per second over an area 1 m^2 with a speed 10^4 m/s , the pressure exerted by the gas molecules will be of the order of:

- (A) $10^8 \frac{\text{N}}{\text{m}^2}$ (B) $10^3 \frac{\text{N}}{\text{m}^2}$
(C) $10^4 \frac{\text{N}}{\text{m}^2}$ (D) $10^{16} \frac{\text{N}}{\text{m}^2}$

2. A particle moves in one dimension from rest under the influence of a force that varies with the distance traveled by that varies with the distance traveled by the particle as shown in the figure. The kinetic energy of the particle after it has traveled 3 m is:

- (A) 2.5 J
(B) 4 J
(C) 5 J
(D) 6.5 J

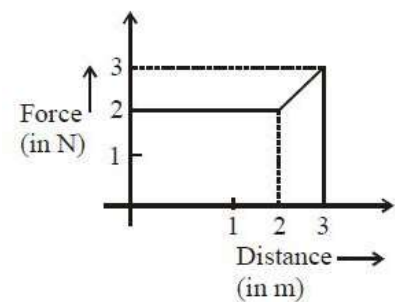

3. An upright object is placed at a distance of 40 cm in front of a convergent lens of focal length 20 cm. A convergent mirror of focal length 10 cm is placed at a distance of 60 cm on the other side of the lens. The position and size of the final image will be:
- (A) 40 cm from the convergent mirror, same size as the object
(B) 20 cm from the convergent mirror, same size as the object
(C) 40 cm from the convergent lens, twice the size of the object
(D) 20 cm from the convergent mirror, twice the size of the object

4. Four particles A, B, C and D with masses $m_A = m$, $m_B = 2m$, $m_C = 3m$ and $m_D = 4m$ are at the corners of a square. They have accelerations of equal magnitude with directions as shown. The acceleration of the centre of mass of the particles is:

- (A) $\frac{a}{5}(\hat{i} - \hat{j})$ (B) Zero
(C) $\frac{a}{5}(\hat{i} + \hat{j})$ (D) $a(\hat{i} + \hat{j})$

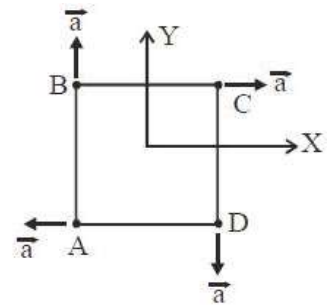

5. Two identical beakers A and B contain equal volumes of two different liquids at 60°C each and left to cool down. Liquid in A has density of $8 \times 10^2 \text{ kg/m}^3$ and specific heat of $2000 \text{ Jkg}^{-1}\text{K}^{-1}$ while liquid in B has density of 10^3 kgm^{-3} and specific heat of $4000 \text{ Jkg}^{-1}\text{K}^{-1}$. Which of the following best describes their temperature versus time graph schematically? (assume the emissivity of both the beakers to be the same)

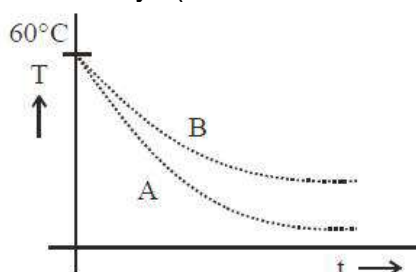

(A)

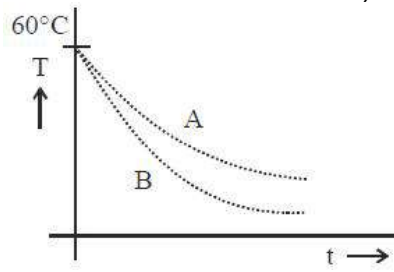

(B)

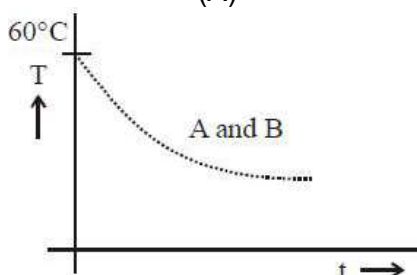

(C)

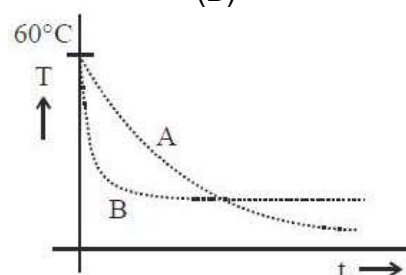

(D)

6. A thin strip 10 cm long is on a U shaped wire of negligible resistance and it is connected to a spring of spring constant 0.5 Nm^{-1} (see figure). The assembly is kept in a uniform magnetic field of 0.1 T. If the strip is pulled from its equilibrium position and released, the number of oscillations it performs before its amplitude decreases by a factor of e is N . If the mass of the strip is 50 grams, its resistance 10Ω and air drag negligible, N will be close to:

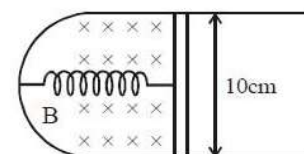

- (A) 50000 (B) 10000
(C) 1000 (D) 5000

7. A 20 Henry inductor coil is connected to a 10 ohm resistance in series as shown in figure. The time at which rate of dissipation of energy (Joule's heat) across resistance is equal to the rate at which magnetic energy is stored in the inductor, is

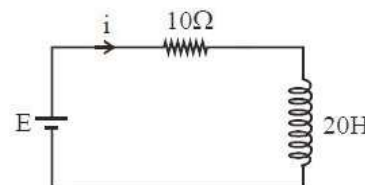

- (A) $\frac{2}{\ln 2}$ (B) $\ln 2$
(C) $\frac{1}{2} \ln 2$ (D) $2 \ln 2$

8. A wire of length $2L$ is made by joining two wires A and B of same lengths but different radii r and $2r$ and made of the same material. It is vibrating at a frequency such that the joint of the two wires forms a node. If the number of antinodes in wire A is p and that in B is q then the ratio $p : q$ is:

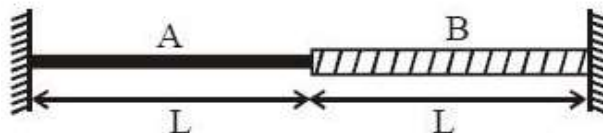

- (A) 1 : 4
(B) 1 : 2
(C) 3 : 5
(D) 4 : 9
9. A steel wire having a radius of 2.0 mm, carrying a load of 4 kg, is hanging from a ceiling. Given that $g = 3.1\pi \text{ms}^{-2}$, what will be the tensile stress that would be developed in the wire?
(A) $6.2 \times 10^6 \text{Nm}^{-2}$
(B) $4.8 \times 10^6 \text{Nm}^{-2}$
(C) $5.2 \times 10^6 \text{Nm}^{-2}$
(D) $3.1 \times 10^6 \text{Nm}^{-2}$
10. Voltage rating of a parallel plate capacitor is 500V. Its dielectric can withstand a maximum electric field of $10^6 \frac{\text{V}}{\text{m}}$. The plate area is 10^{-4}m^2 . What is the dielectric constant if the capacitance is 15 pF? (given $\epsilon_0 = 8.86 \times 10^{-12} \text{C}^2 / \text{Nm}^2$)
(A) 3.8
(B) 6.2
(C) 4.5
(D) 8.5
11. An alternating voltage $v(t) = 220 \sin 100\pi t$ volt is applied to a purely resistive load of 50Ω . The time taken for the current to rise from half of the peak value of the peak value is:
(A) 2.2 ms
(B) 3.3 ms
(C) 5 ms
(D) 7.2 ms
12. The wavelength of the carrier waves in a modern optical fiber communication network is close to:
(A) 1500 nm
(B) 600 nm
(C) 2400 nm
(D) 900 nm
13. Water from a pipe is coming at a rate of 100 litres per minute. If the radius of the pipe is 5 cm, the Reynolds number for the flow is of the order of : (density of water = 1000kg/m^3 , coefficient of viscosity of water = 1mPa s)
(A) 10^3
(B) 10^6
(C) 10^2
(D) 10^4
14. A boy's catapult is made of rubber cord which is 42 cm long, with 6 mm diameter of cross – section and of negligible mass. The boy keeps a stone weighing 0.02 kg on it and stretches the cord by 20 cm by applying a constant force. When released, the stone flies off with a velocity of 20ms^{-1} . Neglect the change in the area of cross section of the cord while stretched. The Young's modulus of rubber is closest to:
(A) 10^3Nm^{-2}
(B) 10^6Nm^{-2}
(C) 10^8Nm^{-2}
(D) 10^4Nm^{-2}

15. Two particles move at right angle to each other. Their de Broglie wavelengths are λ_1 and λ_2 respectively. The particles suffer perfectly inelastic collision. The de Broglie wavelength λ , of the final particle, is given by:

(A) $\lambda = \sqrt{\lambda_1 \lambda_2}$

(B) $\lambda = \frac{\lambda_1 + \lambda_2}{2}$

(C) $\frac{2}{\lambda} = \frac{1}{\lambda_1} + \frac{1}{\lambda_2}$

(D) $\frac{1}{\lambda^2} = \frac{1}{\lambda_1^2} + \frac{1}{\lambda_2^2}$

16. Four identical particles of mass M are located at the corners of a square of side 'a'. What should be their speed if each of them revolves under the influence of other's gravitational field in a circular orbit circumscribing the square?

(A) $1.35\sqrt{\frac{GM}{a}}$

(B) $1.16\sqrt{\frac{GM}{a}}$

(C) $1.41\sqrt{\frac{GM}{a}}$

(D) $1.21\sqrt{\frac{GM}{a}}$

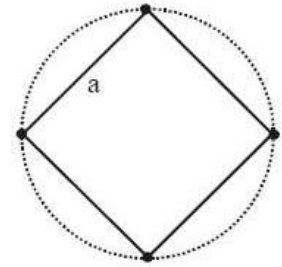

17. In figure, the optical fiber is $l = 2\text{m}$ long and has a diameter of $d = 20\ \mu\text{m}$. If a ray of light is incident on one end of the fiber at angle $\theta_1 = 40^\circ$, the number of reflection it makes before emerging from the other end is close to:

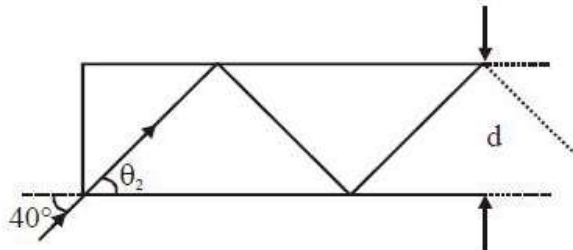

(A) 57000
(C) 66000

(B) 45000
(D) 55000

18. A circular coil having N turns and radius r carries a current. It is held in the XZ plane in a magnetic field $B\hat{i}$. The torque on the coil due to the magnetic field is:

(A) $\frac{Br^2I}{\pi N}$

(B) zero

(C) $\frac{B\pi r^2I}{N}$

(D) $B\pi r^2IN$

19. Ship A is sailing towards north – east with velocity $\vec{v} = 30\hat{i} + 50\hat{j}$ km/hr where \hat{i} points east and \hat{j} , north. Ship B is at a distance of 80 km east and 150 km north of Ship A and is sailing towards west at 10 km/hr. A will be at minimum distance from B ins:

(A) 2.2 hrs.
(C) 2.6 hrs.

(B) 4.2 hrs.
(D) 3.2 hrs.

20. A plane electromagnetic wave travels in free space along the x – direction. The electric field component of the wave at a particular point of space and time is $E = Vm^{-1}$ along y – direction. Its corresponding magnetic field component, B would be:
 (A) $2 \times 10^{-8} T$ along z – direction (B) $6 \times 10^{-8} T$ along x – direction
 (C) $6 \times 10^{-8} T$ along z - direction (D) $2 \times 10^{-8} T$ along y – direction
21. A thermally insulated vessel contains 150 g of water at $0^\circ C$. Then the air from the vessel is pumped out adiabatically. A fraction of water turns into ice and the rest evaporates at $0^\circ C$ itself. The mass of evaporated water will be close to:
 (Latent heat of vaporization of water = $2.10 \times 10^6 Jkg^{-1}$ and Latent heat of Fusion of water = $3.36 \times 10^5 Jkg^{-1}$)
 (A) 35 g (B) 150 g
 (C) 130 g (D) 20 g
22. Radiation coming from transition $n = 2$ to $n = 1$ of hydrogen atoms falls on He^+ ions in $n = 1$ and $n = 2$ states. The possible transitions of helium ions as they absorb energy from the radiation is:
 (A) $n = 2 \rightarrow n = 4$ (B) $n = 2 \rightarrow n = 5$
 (C) $n = 2 \rightarrow n = 3$ (D) $n = 1 \rightarrow n = 4$
23. A 200Ω resistor has a certain color code. If one replaces the red color by green in the code, the new resistance will be:
 (A) 500Ω (B) 400Ω
 (C) 300Ω (D) 100Ω
24. The reverse breakdown voltage of a Zener diode is $5.6 V$ in the given circuit .

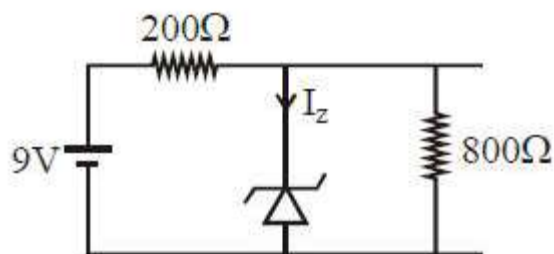

The current I_z through the Zener is:

- (A) 10 mA (B) 15 mA
 (C) 7 mA (D) 17 mA
25. A thin circular plate of mass M and radius R has its density varying as $p(r) = p_0 r$ with P_0 as constant and r is the distance from its center. The moment of Inertia of the circular plate about an axis perpendicular to the plate and passing through its edge is $I = aMR^2$. The value of the coefficient a is:
 (A) $\frac{8}{5}$ (B) $\frac{1}{2}$
 (C) $\frac{3}{5}$ (D) $\frac{3}{2}$

26. In SI units, the dimensions of $\sqrt{\frac{\epsilon_0}{\mu_0}}$ is:

- (A) $AT^{-3}ML^{3/2}$ (B) $A^{-1}TML^3$
 (C) $A^2T^3M^{-1}L^{-2}$ (D) $AT^2M^{-1}L^{-1}$

27. For the circuit shown, with $R_1 = 1.0\Omega$, $R_2 = 2.0\Omega$, $E_1 = 2V$ and $E_2 = E_3 = 4V$, the potential difference between the points 'a' and 'b' is approximately (in V):

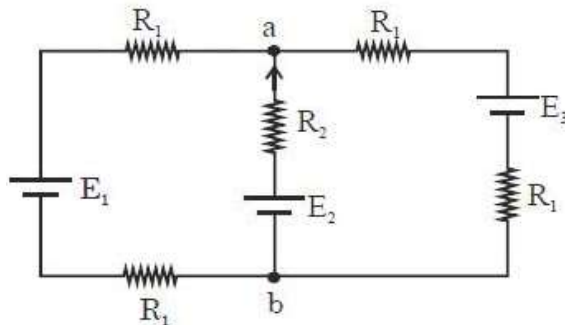

- (A) 3.3 (B) 2.3
 (C) 3.7 (D) 2.7

28. A solid conducting sphere, having a charge Q , is surrounded by an uncharged conducting hollow spherical shell. Let the potential difference between the surface of the solid sphere and that of the outer surface of the hollow shell be V . If the shell is now given a charge of $-4Q$, the new potential difference between the same two surface is:

- (A) $2V$ (B) $-2V$
 (C) $4V$ (D) V

29. In an interference experiment the ratio of amplitudes of coherent waves is $\frac{a_1}{a_2} = \frac{1}{3}$. The ratio of maximum and minimum intensities of fringes will be:

- (A) 9 (B) 4
 (C) 18 (D) 2

30. The bob of a simple pendulum has mass $2g$ and a charge of $5.0\mu C$. It is at rest in a uniform horizontal electric field of intensity $2000\frac{V}{m}$. At equilibrium, the angle that the pendulum makes with the vertical is: (take $g = 10\frac{m}{s^2}$)

- (A) $\tan^{-1}(2.0)$ (B) $\tan^{-1}(0.2)$
 (C) $\tan^{-1}(5.0)$ (D) $\tan^{-1}(0.5)$

PART – B (CHEMISTRY)

31. Element 'B' forms ccp structure and 'A' occupies half of the octahedral voids, while oxygen atoms occupy all the tetrahedral voids. The structure of bimetallic oxide is
 (A) A_2B_2O (B) AB_2O_4
 (C) A_4B_2O (D) A_2BO_4

32. Coupling of benzene diazonium chloride with 1 – naphthol in alkaline medium will give:

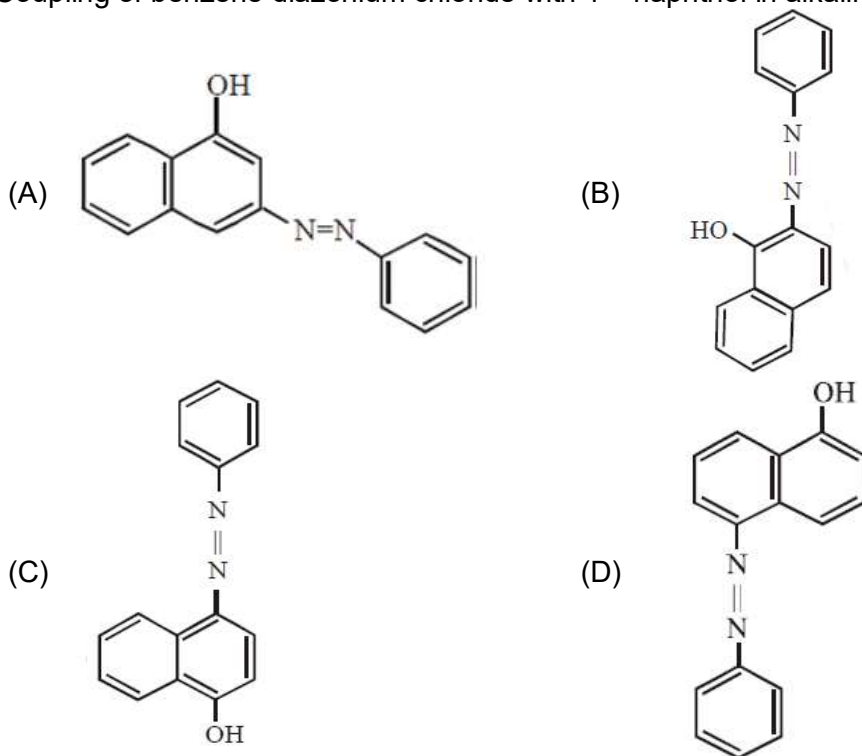

33. The size of the iso-electronic species Cl^- , Ar and Ca^{2+} is affected by
 (A) Principal quantum number of valence shell
 (B) Azimuthal quantum number of valence shell
 (C) electron – electron interaction in the outer orbitals
 (D) nuclear charge
34. In the following compounds, the decreasing order of basic strength will be:
 (A) $C_2H_5NH_2 > NH_3 > (C_2H_5)_2NH$ (B) $NH_3 > C_2H_5NH_2 > (C_2H_5)_2NH$
 (C) $(C_2H_5)_2NH > C_2H_5NH_2 > NH_3$ (D) $(C_2H_5)_2NH > NH_3 > C_2H_5NH_2$
35. The correct order of the spin only magnetic moment of metal ions in the following low spin complexes, $[V(CN)_6]^{4-}$, $[Fe(CN)_6]^{4-}$, $[Ru(NH_3)_6]^{3+}$, and $[Cr(NH_3)_6]^{2+}$, is:
 (A) $Cr^{2+} > Ru^{3+} > Fe^{2+} > V^{2+}$ (B) $V^{2+} > Cr^{2+} > Ru^{3+} > Fe^{2+}$
 (C) $Cr^{2+} > V^{2+} > Ru^{3+} > Fe^{2+}$ (D) $V^{2+} > Ru^{3+} > Cr^{2+} > Fe^{2+}$

36. An organic compound 'X' showing the following solubility profile is:

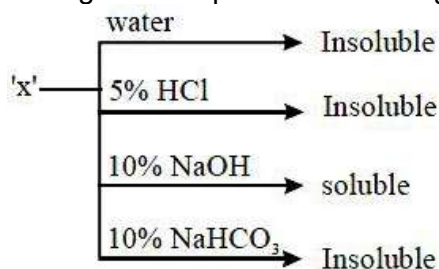

- (A) Oleic acid
(B) o-Toluidine
(C) Benzamide
(D) m-Cresol
37. Diborane (B₂H₆) reacts independently with O₂ and H₂O to produce, respectively:
(A) H₃BO₃ and B₂O₃
(B) B₂O₃ and H₃BO₃
(C) HBO₂ and H₃BO₃
(D) B₂O₃ and [BH₄]⁻
38. The lanthanoid that would show colour is:
(A) Gd³⁺
(B) La³⁺
(C) Lu³⁺
(D) Sm³⁺
39. The major product of the following reaction

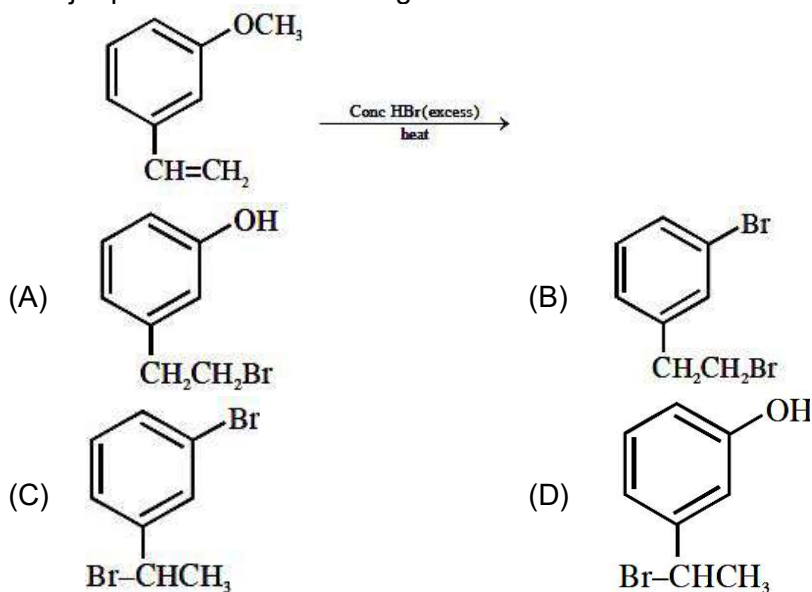

40. 100 mL of a water sample contains 0.81 g of calcium bicarbonate and 0.73 g of magnesium bicarbonate. The hardness of this water sample expressed in terms of equivalents of CaCO₃ is:
(molar mass of calcium bicarbonate is 162 g mol⁻¹ and magnesium bicarbonate is 146 g mol⁻¹)
(A) 10,000 ppm
(B) 1,000 ppm
(C) 5,000 ppm
(D) 100 ppm

41. An organic compound neither reacts with neutral ferric chloride solution nor with Fehling solution. It however, reacts with Grignard reagent and gives positive iodoform test. The compound is:

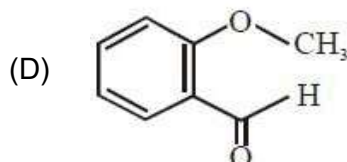
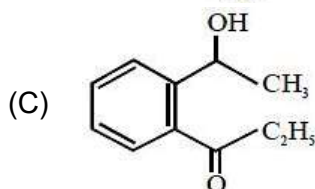
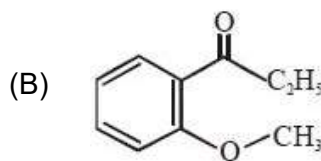
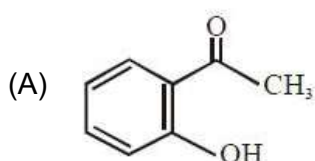

42. For the reaction $2A + B \rightarrow C$, the values of initial rate at different reactant concentrations are given in the table below: The rate law for the reaction is:

[A] (mol L ⁻¹)	[B] (mol L ⁻¹)	Initial Rate (mol L ⁻¹ s ⁻¹)
0.05	0.05	0.045
0.10	0.05	0.090
0.20	0.10	0.72

(A) Rate = $k[A]^2[B]^2$

(B) Rate = $k[A][B]^2$

(C) Rate = $k[A][B]$

(D) Rate = $k[A]^2[B]$

43. The major product of the following reaction is:

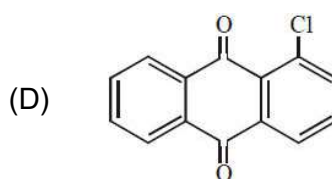
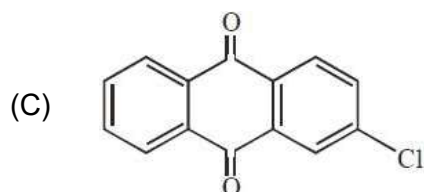
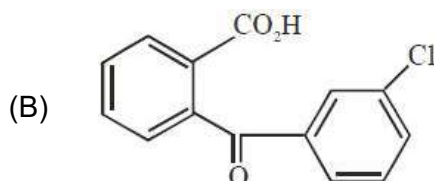
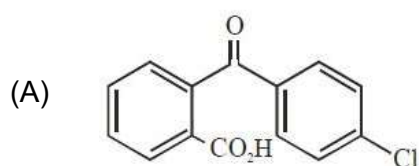
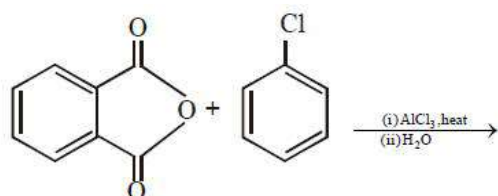

44. Which is wrong with respect to our responsibility as a human being to protect our environment?
- (A) Restricting the use of vehicles
 (B) Using plastic bags
 (C) Setting up compost tin in gardens
 (D) Avoiding the use of floodlighted facilities.

45. The major product of the following reaction

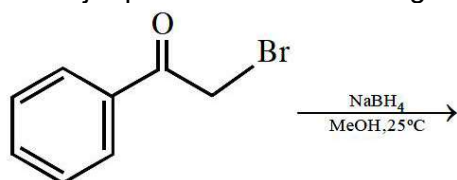

- (A)
- (B)
- (C)
- (D)

46. For silver C_p ($\text{JK}^{-1}\text{mol}^{-1}$) = $23 + 0.01T$. If the temperature (T) of 3 moles of silver is raised from 300 K to 1000 K at 1 atm pressure, the value of ΔH will be close to:
- (A) 13 kJ
 (B) 62 kJ
 (C) 16 kJ
 (D) 21 kJ

47. The correct order of hydration enthalpies of alkali metal ions is:
- (A) $\text{Li}^+ > \text{Na}^+ > \text{K}^+ > \text{Cs}^+ > \text{Rb}^+$
 (B) $\text{Na}^+ > \text{Li}^+ > \text{K}^+ > \text{Rb}^+ > \text{Cs}^+$
 (C) $\text{Na}^+ > \text{Li}^+ > \text{K}^+ > \text{Cs}^+ > \text{Rb}^+$
 (D) $\text{Li}^+ > \text{Na}^+ > \text{K}^+ > \text{Rb}^+ > \text{Cs}^+$

48. Adsorption of a gas follows Freundlich adsorption isotherm. x is the mass of the gas adsorbed on mass m of the adsorbent. The plot of $\log \frac{x}{m}$ versus $\log p$ is shown in the

given graph, $\frac{x}{m}$ is proportional to:

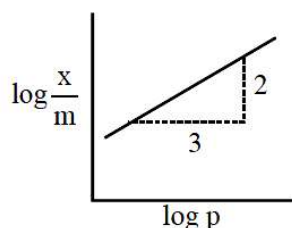

- (A) $p^{2/3}$
 (B) p^2
 (C) p^3
 (D) $p^{3/2}$

49. The vapour pressures of pure liquids A and B are 400 and 600 mm Hg, respectively at 298 K. On mixing the two liquids, the sum of their initial volumes is equal to the volume of the final mixture. The mole fraction of liquid B is 0.5 in the mixture. The vapour pressure of the final solution, the mole fractions of components A and B in vapour phase, respectively are:
 (A) 500 mmHg, 0.4, 0.6 (B) 500 mmHg, 0.5, 0.5
 (C) 450 mmHg, 0.5, 0.5 (D) 450 mmHg, 0.4, 0.6
50. Given that $E_{\text{O}_2/\text{H}_2\text{O}}^0 = +1.23\text{V}$; $E_{\text{S}_2\text{O}_8^{2-}/\text{SO}_4^{2-}}^0 = 2.05\text{V}$; $E_{\text{Br}_2/\text{Br}^-}^0 = +1.09\text{V}$; $E_{\text{Au}^{3+}/\text{Au}}^0 = 1.4\text{V}$. The strongest oxidizing agent is:
 (A) O_2 (B) $\text{S}_2\text{O}_8^{2-}$
 (C) Au^{3+} (D) Br_2
51. The quantum number of four electrons are given below:
 I. $n = 4, l = 2, m_l = -2, m_s = -1/2$
 II. $n = 3, l = 2, m_l = 1, m_s = +1/2$
 III. $n = 4, l = 1, m_l = 0, m_s = +1/2$
 IV. $n = 3, l = 1, m_l = 1, m_s = -1/2$
 The correct order of their increasing energies will be:
 (A) I < III < II < IV (B) I < II < III < IV
 (C) IV < II < III < I (D) IV < III < II < I
52. If solubility product of $\text{Zr}_3(\text{PO}_4)_4$ is denoted by K_{SP} and its molar solubility is denoted by S, then which of the following relation between S and K_{SP} is correct?
 (A) $S = \left(\frac{K_{\text{SP}}}{6912}\right)^{1/7}$ (B) $S = \left(\frac{K_{\text{SP}}}{144}\right)^{1/6}$
 (C) $S = \left(\frac{K_{\text{SP}}}{929}\right)^{1/9}$ (D) $S = \left(\frac{K_{\text{SP}}}{216}\right)^{1/7}$
53. Which of the following amines can be prepared by Gabriel phthalimide reaction?
 (A) t – butylamine (B) n – butylamine
 (C) neo – pentylamine (D) triethylamine
54. Which one of the following equations does not correctly represent the first law of thermodynamics for the given processes involving an ideal gas? (Assume non – expansion work is zero)
 (A) Adiabatic process: $\Delta U = -w$ (B) Isochoric process: $\Delta U = q$
 (C) Cyclic process: $q = -w$ (D) Isothermal process: $q = -w$

55. The following ligand is:

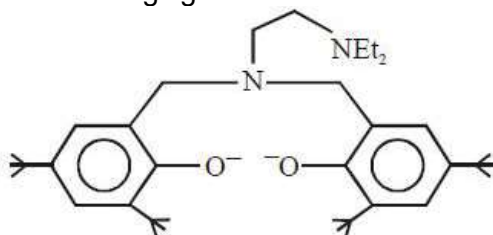

- (A) tridentate
(B) bidentate
(C) tetradentate
(D) hexadentate

56. The IUPAC name of the following compound is

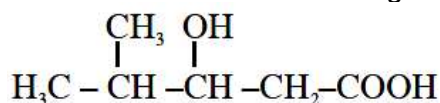

- (A) 3-Hydroxy – 4 – methylpentanoic acid
(B) 4 – Methyl – 3 – hydroxypentanoic acid
(C) 2 – Methyl – 3 – hydroxypentan-5-oic acid
(D) 4, 4 – Dimethyl – 3 – hydroxybutanoic acid

57. In order to oxidize a mixture of one mole of each of FeC_2O_4 , $\text{Fe}_2(\text{C}_2\text{O}_4)_3$, FeSO_4 and $\text{Fe}_2(\text{SO}_4)_3$ in acidic medium, the number of moles of KMnO_4 required is:

- (A) 1
(B) 1.5
(C) 2
(D) 3

58. Assertion : Ozone is destroyed by CFCs in the upper stratosphere.

Reason : Ozone holes increase the amount of UV radiation reaching the earth.

- (A) Assertion and reason are incorrect
(B) Assertion is false, but the reason is correct
(C) Assertion and reasons are both correct, and the reason is the correct explanation for the assertion.
(D) Assertion and reason are correct, but the reason is not the explanation for the assertion.

59. Maltose on treatment with dilute HCl gives:

- (A) D – Fructose
(B) D – Galactose
(C) D – Glucose and D – Fructose
(D) D – Glucose

60. With respect to an ore, Ellingham diagram helps to predict the feasibility of its

- (A) Electrolysis
(B) Thermal reduction
(C) Vapour phase refining
(D) Zone refining

PART-C (MATHEMATICS)

61. The magnitude of the projection of the vector $2\hat{i} + 3\hat{j} + \hat{k}$ on the vector perpendicular to the plane containing the vectors $\hat{i} + \hat{j} + \hat{k}$ and $\hat{i} + 2\hat{j} + 3\hat{k}$, is:
- (A) $3\sqrt{6}$ (B) $\frac{\sqrt{3}}{2}$
(C) $\sqrt{6}$ (D) $\sqrt{\frac{3}{2}}$
62. The shortest distance between the line $y = x$ and the curve $y^2 = x - 2$ is:
- (A) $\frac{11}{4\sqrt{2}}$ (B) 2
(C) $\frac{7}{4\sqrt{2}}$ (D) $\frac{7}{8}$
63. If α and β be the roots of the equation $x^2 - 2x + 2 = 0$, then the least value of n for which $\left(\frac{\alpha}{\beta}\right)^n = 1$ is:
- (A) 4 (B) 2
(C) 5 (D) 3
64. All possible numbers are formed using the digits 1, 1, 2, 2, 2, 2, 3, 4, 4 taken all at a time. The number of such numbers in which the odd digits occupy even places is:
- (A) 180 (B) 175
(C) 162 (D) 160
65. $\int \frac{\sin \frac{5x}{2}}{\sin \frac{x}{2}} dx$ is equal to:
- (where c is a constant of integration).
- (A) $x + 2\sin x + 2\sin 2x + c$ (B) $2x + \sin x + 2\sin 2x + c$
(C) $x + 2\sin x + \sin 2x + c$ (D) $2x + \sin x + \sin 2x + c$
66. Let O (0, 0) and A (0, 1) be two fixed points. Then the locus of a point P such that the perimeter of $\triangle AOP$, is 4, is:
- (A) $9x^2 - 8y^2 + 8y = 16$ (B) $8x^2 + 9y^2 - 9y = 18$
(C) $9x^2 + 8y^2 - 8y = 16$ (D) $8x^2 - 9y^2 + 9y = 18$

67. If $\cos(\alpha + \beta) = \frac{3}{5}$, $\sin(\alpha - \beta) = \frac{5}{13}$ and $0 < \alpha, \beta < \frac{\pi}{4}$, then $\tan(2\alpha)$ is equal to:
- (A) $\frac{63}{52}$ (B) $\frac{33}{52}$
 (C) $\frac{63}{16}$ (D) $\frac{21}{16}$
68. Let $A = \begin{pmatrix} \cos \alpha & -\sin \alpha \\ \sin \alpha & \cos \alpha \end{pmatrix}$, ($\alpha \in \mathbb{R}$) such that $A^{32} = \begin{pmatrix} 0 & -1 \\ 1 & 0 \end{pmatrix}$. Then a value of α is:
- (A) 0 (B) $\frac{\pi}{16}$
 (C) $\frac{\pi}{32}$ (D) $\frac{\pi}{64}$
69. If $f(x) = \log_e \left(\frac{1-x}{1+x} \right)$, $|x| < 1$, then $f\left(\frac{2x}{1+x^2}\right)$ is equal to:
- (A) $2f(x)$ (B) $(f(x))^2$
 (C) $2f(x^2)$ (D) $-2f(x)$
70. If $2y = \left(\cot^{-1} \left(\frac{\sqrt{3} \cos x + \sin x}{\cos x - \sqrt{3} \sin x} \right) \right)^2$, $x \in \left(0, \frac{\pi}{2} \right)$ then $\frac{dy}{dx}$ is equal to
- (A) $\frac{\pi}{6} - x$ (B) $\frac{\pi}{3} - x$
 (C) $x - \frac{\pi}{6}$ (D) $2x - \frac{\pi}{3}$
71. The sum of the solutions of the equation $|\sqrt{x} - 2| + \sqrt{x}(\sqrt{x} - 4) + 2 = 0$, ($x > 0$) is equal to:
- (A) 9 (B) 4
 (C) 10 (D) 12
72. $\lim_{x \rightarrow 0} \frac{\sin^2 x}{\sqrt{2} - \sqrt{1 + \cos x}}$ equals
- (A) $\sqrt{2}$ (B) $4\sqrt{2}$
 (C) 4 (D) $2\sqrt{2}$
73. $2 \cdot {}^{20}C_0 + 5 \cdot {}^{20}C_1 + 8 \cdot {}^{20}C_2 + 11 \cdot {}^{20}C_3 + \dots + 62 \cdot {}^{20}C_{20}$ is equal to
- (A) 2^{23} (B) 2^{26}
 (C) 2^{24} (D) 2^{25}

74. Let $y = y(x)$ be the solutions of the differential equation, $(x^2 + 1)^2 \frac{dy}{dx} + 2x(x^2 + 1)y = 1$ such that $y(0) = 0$. If $\sqrt{a}y(1) = \frac{\pi}{32}$, then the value of 'a' is
- (A) $\frac{1}{2}$ (B) 1
(C) $\frac{1}{16}$ (D) $\frac{1}{4}$
75. If $f(x) = \frac{2 - x \cos x}{2 + x \cos x}$ and $g(x) = \log_e x, (x > 0)$ then the value of the integral $\int_{-\pi/4}^{\pi/4} g(f(x)) dx$ is:
- (A) $\log_e 1$ (B) $\log_e 2$
(C) $\log_e e$ (D) $\log_e 3$
76. The area (in sq. units) of the region $A = \{(x, y) \in \mathbb{R} \times \mathbb{R} \mid 0 \leq x \leq 3, 0 \leq y \leq 4, y \leq x^2 + 3x\}$ is:
- (A) $\frac{26}{3}$ (B) $\frac{59}{6}$
(C) $\frac{53}{6}$ (D) 8
77. The mean and variance of seven observations are 8 and 16, respectively. If 5 of the observations are 2, 4, 10, 12, 14, then the product of the remaining two observations is:
- (A) 40 (B) 45
(C) 49 (D) 48
78. The length of the perpendicular from the point $(2, -1, 4)$ on the straight line, $\frac{x+3}{10} = \frac{y-2}{-7} = \frac{z}{1}$ is:
- (A) greater than 2 but less than 3 (B) less than 2
(C) greater than 4 (D) greater than 3 but less than 4
79. The contrapositive of the statement "If you are born in India, then you are a citizen of India", is:
- (A) If you are a citizen of India, then you are born in India
(B) If you are not a citizen of India, then you are not born in India
(C) If you are not born in India, then you are not a citizen of India
(D) If you are born in India, then you are not a citizen of India
80. The sum of all natural numbers 'n' such that $100 < n < 200$ and H.C.F (91, n) > 1 is:
- (A) 3221 (B) 3303
(C) 3203 (D) 3121

81. If S_1 and S_2 are respectively the sets of local minimum and local maximum points of the function. $f(x) = 9x^4 + 12x^3 - 36x^2 + 25, x \in \mathbb{R}$, then
- (A) $S_1 = \{-2, 1\}; S_2 = \{0\}$
 (B) $S_1 = \{-2, 0\}; S_2 = \{1\}$
 (C) $S_1 = \{-2\}; S_2 = \{0, 1\}$
 (D) $S_1 = \{-1\}; S_2 = \{0, 2\}$
82. The sum of the co-efficient of all even degree terms in x in the expansion of $(x + \sqrt{x^3 - 1})^6 + (x - \sqrt{x^3 - 1})^6, (x > 1)$ is equal to:
- (A) 26 (B) 24
 (C) 32 (D) 29
83. A point on the straight line, $3x + 5y = 15$ which is equidistant from the coordinate, axes will lie only in:
- (A) 4th quadrant (B) 1st, 2nd and 4th quadrants
 (C) 1st quadrant (D) 1st and 2nd quadrants
84. If the tangents on the ellipse $4x^2 + y^2 = 8$ at the points $(1, 2)$ and (a, b) are perpendicular to each other, then a^2 is equal to:
- (A) $\frac{2}{17}$ (B) $\frac{4}{17}$
 (C) $\frac{64}{17}$ (D) $\frac{128}{17}$
85. If $\alpha = \cos^{-1}\left(\frac{3}{5}\right), \beta = \tan^{-1}\left(\frac{1}{3}\right)$, where $0 < \alpha, \beta < \frac{\pi}{2}$, then $\alpha - \beta$ is equal to:
- (A) $\sin^{-1}\left(\frac{9}{5\sqrt{10}}\right)$ (B) $\cos^{-1}\left(\frac{9}{5\sqrt{10}}\right)$
 (C) $\tan^{-1}\left(\frac{9}{5\sqrt{10}}\right)$ (D) $\tan^{-1}\left(\frac{9}{14}\right)$
86. The equation of a plane containing the line of intersection of the planes $2x - y - 4 = 0$ and $y + 2z - 4 = 0$ and passing through the point $(1, 1, 0)$ is:
- (A) $x + 3y + z = 4$ (B) $2x - z = 2$
 (C) $x - 3y - 2z = -2$ (D) $x - y - z = 0$
87. The sum of the squares of the lengths of the chords intercepted on the circle, $x^2 + y^2 = 16$, by the lines, $x + y = n, n \in \mathbb{N}$, where \mathbb{N} is the set of all natural numbers is:
- (A) 320 (B) 160
 (C) 105 (D) 210

88. The greatest value of $c \in \mathbb{R}$ for which the system of linear equations

$$x - cy - cz = 0$$

$$cx - y + cz = 0$$

$$cx + cy - z = 0$$

has a non-trivial solution, is:

(A) -1

(C) $\frac{1}{2}$

(B) 2

(D) 0

89. Let $f : [0, 2] \rightarrow \mathbb{R}$ be a twice differentiable function such that $f''(x) > 0$, for all $x \in (0, 2)$. If

$\phi(x) = f(x) + f(2-x)$, then ϕ is:

(A) increasing on $(0, 2)$

(B) decreasing on $(0, 2)$

(C) decreasing on $(0, 1)$ and increasing on $(1, 2)$

(D) increasing on $(0, 1)$ and decreasing on $(1, 2)$

90. Let A and B be two non-null events such that $A \subset B$. Then, which of the following statements is always correct?

(A) $P(A|B) = 1$

(B) $P(A|B) \leq P(A)$

(C) $P(A|B) = P(B) - P(A)$

(D) $P(A|B) \geq P(A)$

HINTS AND SOLUTIONS

PART A – PHYSICS

1. Pressure is defined as normal force per unit area.
Force is calculated as change in momentum/ time.

By this answer is 2N/m^2

None of the option matches so this question must be Bonus.

Detailed solution is as following:

Magnitude of change in momentum per collision = $2mv$

$$\begin{aligned} \text{Pressure} &= \frac{\text{Force}}{\text{Area}} = \frac{N(2mv)}{1} \\ &= \frac{10^{22} \times 2 \times 10^{-26} \times 10^4}{1} \\ &= 2 \text{ N/m}^2 \end{aligned}$$

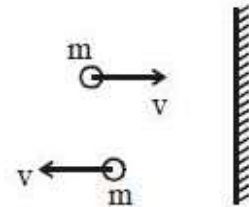

2. According to work energy theorem.
Work done by force on the particle = Change in KE
Work done = Area under F-x graph = $\int F \cdot dx =$

$$2 \times 2 + \frac{(2+3) \times 1}{2}$$

$$W = KE_{\text{final}} - KE_{\text{initial}} = 6.5$$

$$KE_{\text{initial}} = 0$$

$$KE_{\text{final}} = 6.5 \text{ J}$$

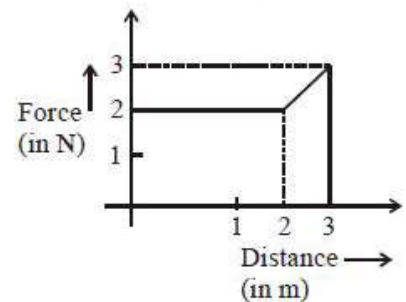

3. There will be 3 phenomenon

- (i) Refraction from lens
- (ii) Reflection from mirror
- (iii) Refraction from lens

After these phenomena. Image will be on object and will have same size.

None of the option depicts so this question is Bonus.

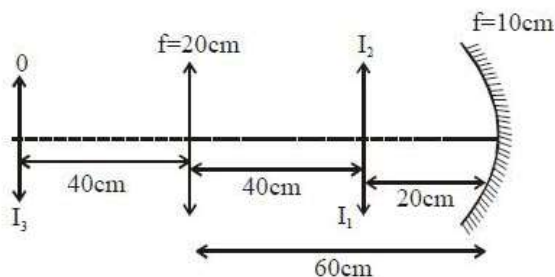

1st refraction $u = -40 \text{ cm}$; $f = +20 \text{ cm}$

$\Rightarrow v = +40 \text{ cm}$ (image I_1) and $m_1 = -1$
for reflection

$u = -20 \text{ cm}$; $f = -10 \text{ cm}$

$\Rightarrow v = -20 \text{ cm}$ (image I_2) and $m_2 = -1$

2nd refraction

$u = -40 \text{ cm}$; $f = +20 \text{ cm}$

$\Rightarrow v = +40 \text{ cm}$ (image I_3) and $m_3 = -1$

Total magnification = $m_1 \times m_2 \times m_3 = -1$ and final image is formed at distance 40 cm from convergent lens and is of same size as the object.

4. $\vec{a}_A = -a\hat{i}$; $\vec{a}_B = a\hat{j}$
 $\vec{a}_C = a\hat{i}$; $\vec{a}_D = -a\hat{j}$
 $\vec{a}_{cm} = \frac{m_a\vec{a}_a + m_b\vec{a}_b + m_c\vec{a}_c + m_d\vec{a}_d}{m_a + m_b + m_c + m_d}$
 $\vec{a}_{cm} = \frac{-ma\hat{i} + 2m\hat{j} + 3ma\hat{i} - 4ma\hat{j}}{10m}$
 $= \frac{2ma\hat{i} - 2ma\hat{j}}{10m} = \frac{a}{5}\hat{i} - \frac{a}{5}\hat{j} = \frac{a}{5}(\hat{i} - \hat{j})$

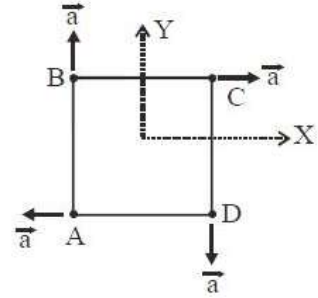

5. $-ms \frac{dT}{dt} = e\sigma A(T^4 - T_0^4)$
 $-\frac{dT}{dt} = \frac{e\sigma A}{ms}(T^4 - T_0^4)$; $-\frac{dT}{dt} = \frac{4e\sigma AT_0^3}{ms}(\Delta T)$

$T = T_0 + (T_i - T_0)e^{-kt}$

where $k = \frac{4e\sigma AT_0^3}{ms}$

$k = \frac{4e\sigma AT_0^3}{\rho v s}$; $\left| \frac{dT}{dt} \right| \propto k$

$\therefore \left| \frac{dT}{dt} \right| \propto \frac{1}{\rho s}$

$\rho_A S_A = 2000 \times 8 \times 10^2 = 16 \times 10^5$

$\rho_B S_B = 4000 \times 10^3 = 4 \times 10^6$

$\rho_A S_A < \rho_B S_B$

$\left| \frac{dT}{dt} \right|_A > \left| \frac{dT}{dt} \right|_B$

6. $T_0 = 2\pi\sqrt{\frac{m}{k}} = \frac{2\pi}{\sqrt{10}}$

$A = A_0 e^{-1/\gamma}$

\therefore for $A = \frac{A_0}{e}$, $t = \gamma$

$t = \gamma = \frac{2m}{b} = \frac{2m}{\frac{B^2 \ell^2}{R}} = 10^4 \text{ s}$

\therefore No of oscillation $\frac{t}{T_0} = \frac{10^4}{2\pi/\sqrt{10}} \approx 5000$.

7. $LID = I^2 R$
 $L \times \frac{E}{10} (-e^{-t/2}) \times \frac{-1}{2} = \frac{E}{10} (1 - e^{-t/2}) \times 10$
 $e^{-t/2} = 1 - e^{-t/2} ; t = 2 \ln 2$

8. Let mass per unit length of wires are μ_1 and μ_2 respectively.

\therefore Materials are same, so density ρ is same.

$$\therefore \mu_1 = \frac{\rho \pi r^2 L}{L} = \mu \text{ and } \mu_2 = \frac{\rho 4\pi r^2 L}{L} = 4\mu$$

Tension in both are same = T, let speed of wave in wires are V_1 and V_2

$$V_1 = \frac{V_1}{2L} = \frac{V}{2L} \text{ \& } f_{02} = \frac{V_2}{2L} = \frac{V}{4L}$$

Frequency at which both resonate is L.C.M. of both frequencies i.e. $\frac{V}{2L}$.

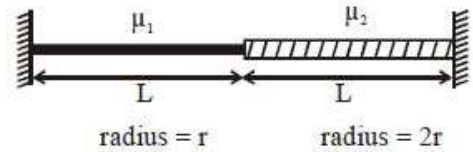

Hence number of loops in wires are 1 and 2 respectively

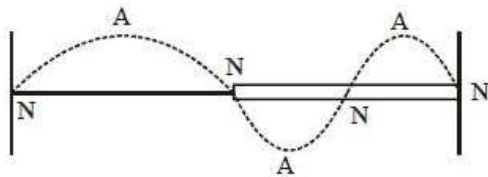

So, ratio of number of antinodes is 1 : 2.

9. Tensile stress in wire will be

$$= \frac{\text{Tensile force}}{\text{Cross section Area}}$$

$$= \frac{mg}{\pi R^2} = \frac{4 \times 3.1\pi}{\pi \times 4 \times 10^{-6}} \text{ Nm}^{-2} = 3.1 \times 10^6 \text{ Nm}^{-2}$$

10. $A = 10^{-4} \text{ m}^2$
 $E_{\text{max}} = 10^6 \text{ V/m}$
 $C = 15 \mu\text{F}$

$$C = \frac{k\epsilon_0 A}{d} ; \frac{Cd}{\epsilon_0 A} = k$$

$$k = \frac{15 \times 10^{-12} \times 500 \times 10^{-6}}{8.86 \times 10^{-12} \times 10^4} = \frac{15 \times 5}{8.86} = 8.465$$

$k \approx 8.5$

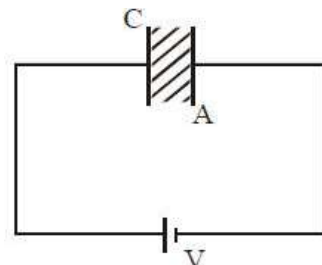

11. $V(t) = 220 \sin(100 \pi t)$ volt time taken,

$$t = \frac{\theta}{\omega} = \frac{\frac{\pi}{3}}{100\pi} = \frac{1}{300} \text{ sec}$$

$$= 3.3 \text{ ms}$$

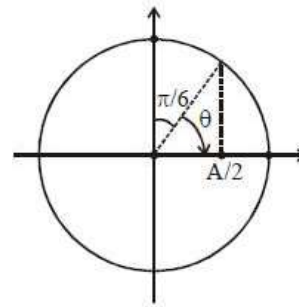

12. To minimize attenuation, wavelength of carrier waves is close to 1500 nm.

13. Reynolds number = $\frac{\rho v d}{\eta}$

Volume flow rate = $v \times \pi r^2$

$$v = \frac{100 \times 10^{-3}}{60} \times \frac{1}{\pi \times 25 \times 10^{-4}}$$

$$v = \frac{2}{3\pi} \text{ m/s}$$

$$\text{Reynolds number} = \frac{10^3 \times 2 \times 10 \times 10^{-2}}{10^{-3} \times 3\pi} = 2 \times 10^4$$

Order 10^4

14. Energy of catapult = $\frac{1}{2} \times \left(\frac{\Delta \ell}{\ell}\right)^2 \times Y \times A \times \ell$

= Kinetic energy of the ball = $\frac{1}{2} m v^2$

$$\text{Therefore, } \frac{1}{2} \times \left(\frac{20}{42}\right)^2 \times Y \times \pi \times 3^2 \times 10^{-6} \times 42 \times 10^{-2} = \frac{1}{2} \times 2 \times 10^{-2} \times (20)^2$$

$$Y = 3 \times 10^6 \text{ Nm}^2$$

- 15.

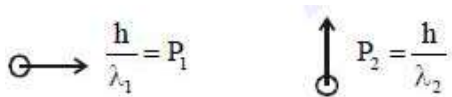

$$\vec{P}_1 = \frac{h}{\lambda_1} \hat{i} \quad \text{and} \quad \vec{P}_2 = \frac{h}{\lambda_2} \hat{j}$$

Using momentum conservation

$$\vec{P} = \vec{P}_1 + \vec{P}_2 = \frac{h}{\lambda_1} \hat{i} + \frac{h}{\lambda_2} \hat{j}$$

$$|\vec{P}| = \sqrt{\left(\frac{h}{\lambda_1}\right)^2 + \left(\frac{h}{\lambda_2}\right)^2}$$

$$\frac{h}{\lambda} = \sqrt{\left(\frac{h}{\lambda_1}\right)^2 + \left(\frac{h}{\lambda_2}\right)^2}$$

$$\frac{1}{\lambda^2} = \frac{1}{\lambda_1^2} + \frac{1}{\lambda_2^2}$$

16. Net force on particle towards centre of circle is

$$F_c = \frac{GM^2}{2a^2} + \frac{GM^2}{a^2} \sqrt{2}$$

$$= \frac{GM^2}{a^2} \left(\frac{1}{2} + \sqrt{2} \right)$$

This force will act as centripetal force. Distance of particle from centre of circle is

$$\frac{a}{\sqrt{2}}$$

$$r = \frac{a}{\sqrt{2}}, F_c = \frac{mv^2}{r}$$

$$\frac{mv^2}{\frac{a}{\sqrt{2}}} = \frac{GM^2}{a^2} \left(\frac{1}{2} + \sqrt{2} \right)$$

$$v^2 = \frac{GM}{a} \left(\frac{1}{2\sqrt{2}} + 1 \right)$$

$$v^2 = \frac{GM}{a} (1.35) ; v = 1.16 \sqrt{\frac{GM}{a}}$$

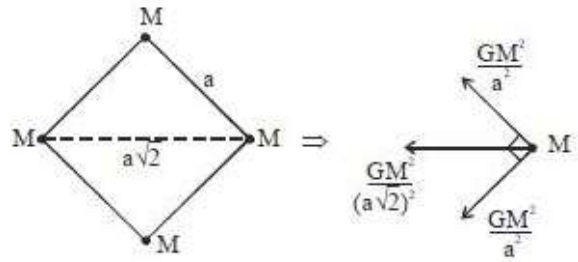

17. If we approximate the angle θ_2 as 30° initially then answer will be closer to 57000. but if we solve thoroughly, answer will be close to 55000. So both the answers must be awarded. Detailed solution as following.

Exact solution

By Snell's law $1 \cdot \sin 40^\circ = (1.31) \sin \theta_2$

$$\sin \theta_2 = \frac{.64}{1.31} = \frac{64}{131} \approx .49$$

$$\text{Now } \tan \theta_2 = \frac{64}{\sqrt{(131)^2 - (64)^2}} = \frac{64}{\sqrt{13065}} \approx \frac{64}{114.3} = \frac{d}{x}$$

Now number of reflections

$$= \frac{2 \times 64}{114.3 \times 20 \times 10^{-6}} = \frac{64 \times 10^5}{114.3}$$

$$\approx 55991 \approx 55000$$

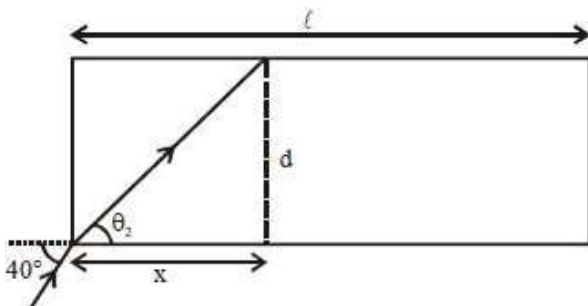

Approximate solution

By Snell's law $1 \cdot \sin 40^\circ = (1.31) \sin \theta_2$

$$\sin \theta_2 = \frac{0.64}{1.31} = \frac{64}{131} \approx 0.49$$

If assume $\Rightarrow \theta_2 \approx 30^\circ$

$$\tan 30^\circ = \frac{d}{x} \Rightarrow x = \sqrt{3}d$$

Now number of reflections

$$= \frac{\ell}{\sqrt{3}d} = \frac{2}{\sqrt{3} \times 20 \times 10^{-6}} = \frac{10^5}{\sqrt{3}}$$

$$\approx 57735 \approx 57000$$

18. Magnetic moment of coil = $NIA \hat{j}$
 $= NI(\pi r^2) \hat{j}$

Torque on loop (coil) = $\vec{M} \times \vec{B}$
 $= NI(\pi r^2) B \sin 90^\circ (-\hat{k})$
 $= NI\pi r^2 B (-\hat{k})$

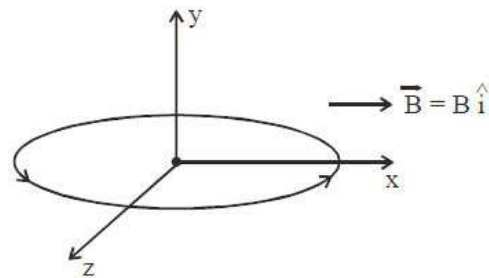

19. If we take the position of ship 'A' as origin then positions and velocities of both ships can be given as:

$$\vec{v}_A = (30\hat{i} + 50\hat{j}) \text{ km/hr}$$

$$\vec{v}_B = -10\hat{i} \text{ km/hr} ; \quad \vec{r}_A = 0\hat{i} + 0\hat{j}$$

$$\vec{r}_B = (80\hat{i} + 150\hat{j}) \text{ km}$$

Time after which distance between them will be minimum

$$t = -\frac{\vec{r}_{BA} \cdot \vec{v}_{BA}}{|\vec{v}_{BA}|^2} ;$$

Where $\vec{r}_{BA} = (80\hat{i} + 150\hat{j}) \text{ km}$

$$\vec{v}_{BA} = -10\hat{i} - (30\hat{i} + 50\hat{j}) = (-40\hat{i} - 50\hat{j}) \text{ km/hr}$$

$$\therefore t = -\frac{(80\hat{i} + 150\hat{j}) \cdot (-40\hat{i} - 50\hat{j})}{|-40\hat{i} - 50\hat{j}|^2}$$

$$= \frac{3200 + 7500}{4100} \text{ hr} = \frac{10700}{4100} \text{ hr} = 2.6 \text{ hrs}$$

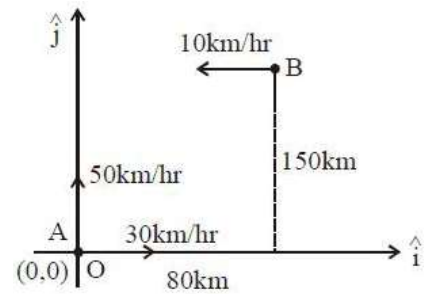

20. The direction of propagation of an EM wave is direction of $\vec{E} \times \vec{B}$.

$$\hat{i} = \hat{j} \times \hat{B}$$

$$\Rightarrow \hat{B} = \hat{k}$$

$$C = \frac{E}{B} \Rightarrow B = \frac{E}{C} = \frac{6}{3 \times 10^8}$$

$B = 2 \times 10^{-8} \text{ T}$ along z direction.

21. Suppose 'm' gram of water evaporates then, heat required

$$\Delta Q_{\text{req}} = mL_v$$

Mass that converts into ice = (150 - m)

So, heat released in this process

$$\Delta Q_{\text{rel}} = (150 - m) L_f$$

Now,

$$\Delta Q_{\text{rel}} = \Delta Q_{\text{req}}$$

$$(150 - m) L_f = mL_v$$

$$M(L_f + L_v) = 150 L_f$$

$$m = \frac{150L_f}{L_f + L_v} ; m = 20 \text{ g}$$

22. Energy released for transition n = 2 to n = 1 of hydrogen atom

$$E = 13.6Z^2 \left(\frac{1}{n_1^2} - \frac{1}{n_2^2} \right)$$

$$Z = 1, n_1 = 1, n_2 = 2$$

$$E = 13.6 \times 1 \times \left(\frac{1}{1^2} - \frac{1}{2^2} \right)$$

$$E = 13.6 \times \frac{3}{4} \text{ eV}$$

For He⁺ ion z = 2

(A) n = 1 to n = 4

$$E = 13.6 \times 2^2 \times \left(\frac{1}{1^2} - \frac{1}{4^2} \right) = 13.6 \times \frac{15}{4} \text{ eV}$$

(B) n = 2 to n = 4

$$E = 13.6 \times 2^2 \times \left(\frac{1}{1^2} - \frac{1}{4^2} \right) = 13.6 \times \frac{3}{4} \text{ eV}$$

(C) n = 2 to n = 5

$$E = 13.6 \times 2^2 \times \left(\frac{1}{2^2} - \frac{1}{5^2} \right) = 13.6 \times \frac{21}{25} \text{ eV}$$

(D) n = 2 to n = 3

$$E = 13.6 \times 2^2 \times \left(\frac{1}{2^2} - \frac{1}{3^2} \right) = 13.6 \times \frac{5}{9} \text{ eV}$$

23. When red is replaced with green 1st digit changes to 5 so new resistance will be 500 Ω.

24. $9 = V_Z + V_{R_1}$

$$V_Z = 5.6 \text{ V}$$

$$V_{R_1} = 9 - 5.6$$

$$V_{R_1} = 3.4$$

$$I_{R_1} = \frac{V_{R_1}}{R} = \frac{3.4}{200} ; I_{R_1} = 17 \text{ mA}$$

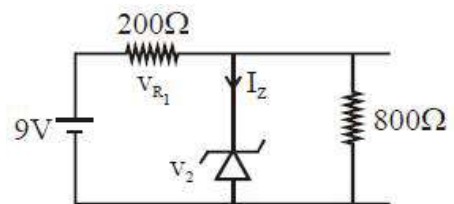

$$V_z = V_{R_2} = I_{R_2} (R_2)$$

$$\frac{5.6}{800} = I_{R_2} \quad ; \quad I_{R_2} = 7 \text{ mA}$$

$$I_z = (17 - 7) \text{ mA} = 10 \text{ mA}$$

$$25. \quad M = \int_0^R \rho_0 r (2\pi r dr) = \frac{\rho_0 \times 2\pi \times R^3}{3}$$

$$I_0 \text{ (MOI about COM)} = \int_0^R \rho_0 r (2\pi r dr) \times r^2 = \frac{\rho_0 \times 2\pi R^5}{5}$$

By parallel axis theorem

$$I = I_0 + MR^2$$

$$= \frac{\rho_0 \times 2\pi R^5}{5} + \frac{\rho_0 \times 2\pi R^3}{3} \times R^2 = \rho_0 2\pi R^5 \times \frac{8}{15}$$

$$= MR^2 \times \frac{8}{5}$$

$$26. \quad \text{Dimension of } \sqrt{\frac{\epsilon_0}{\mu_0}}$$

$$[\epsilon_0] = [M^{-1}L^{-3}T^4A^2]$$

$$[\mu_0] = [MLT^{-2}A^{-2}]$$

$$\text{Dimension of } \sqrt{\frac{\epsilon_0}{\mu_0}} = \left[\frac{M^{-1}L^{-3}T^4A^2}{MLT^{-2}A^{-2}} \right]^{\frac{1}{2}}$$

$$= [M^{-2}L^{-4}T^6A^4]^{1/2}$$

$$= [M^{-1}L^{-2}T^3A^2]$$

$$27. \quad E_{eq} = \frac{\frac{E_1}{2R_1} + \frac{E_2}{R_2} + \frac{E_3}{2R_1}}{\frac{1}{2R_1} + \frac{1}{R_2} + \frac{1}{2R_1}}$$

$$= \frac{\frac{2}{1} + \frac{4}{1} + \frac{4}{1}}{\frac{2}{2} + \frac{4}{2} + \frac{4}{2}} = \frac{5}{3} = \frac{10}{3} = 3.3$$

28. As given in the first condition:

Both conducting spheres are shown.

$$V_{in} - V_{out} = \left(\frac{kQ}{r_1} \right) - \left(\frac{kQ}{r_2} \right)$$

$$= kQ \left(\frac{1}{r_1} - \frac{1}{r_2} \right) = V$$

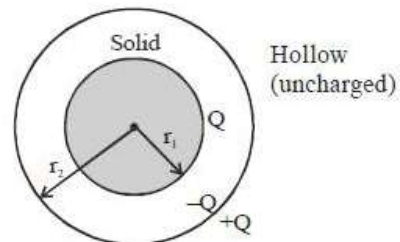

In the second condition:

Shell is now given charge $-4Q$.

$$V_{\text{in}} - V_{\text{out}} = \left(\frac{kQ}{r_1} - \frac{4kQ}{r_2} \right) - \left(\frac{kQ}{r_2} - \frac{4kQ}{r_2} \right)$$

$$= \frac{kQ}{r_1} - \frac{kQ}{r_2}$$

$$= kQ \left(\frac{1}{r_1} - \frac{1}{r_2} \right) = V$$

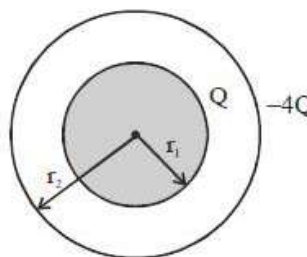

Hence, we also obtain that potential difference does not depend on charge of outer sphere.

\therefore P. d. remains same.

29. Given $\frac{a_1}{a_2} = \frac{1}{3}$

Ratio of intensities, $\frac{I_1}{I_2} = \left(\frac{a_1}{a_2} \right)^2 = \frac{1}{9}$

Now, $\frac{I_{\text{max}}}{I_{\text{min}}} = \left(\frac{\sqrt{I_1} + \sqrt{I_2}}{\sqrt{I_1} - \sqrt{I_2}} \right)^2 = \left(\frac{1+3}{1-3} \right)^2 = 4$

30. $\tan \theta = \frac{qE}{mg} = \frac{5 \times 10^{-6} \times 2000}{2 \times 10^{-3} \times 10}$

$\tan \theta = \frac{1}{2} \Rightarrow \theta = \tan^{-1}(0.5)$

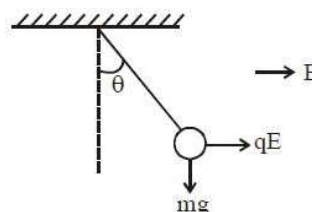

PART B – CHEMISTRY

31. For cubic unit cell, only FCC has octahedral and tetrahedral voids.

$$Z_B = 4, Z_A = 4 \times \frac{1}{4} = 2, Z_O = 8$$

$$\text{Formula} = A_2B_2O_8 = AB_2O_4$$

32. Electrophilic substitution reaction takes place.

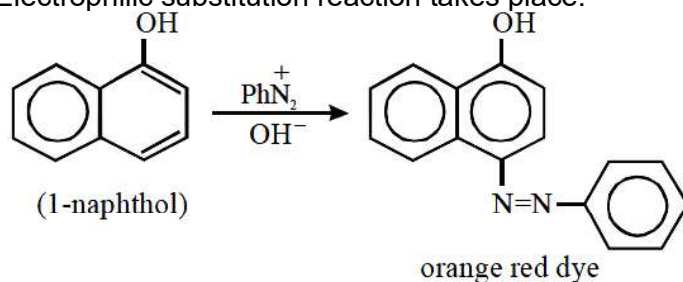

33. For isoelectronic species the size is compared by nuclear charge.

$$\text{Size} \propto \frac{1}{Z(\text{Nuclear Charge})}$$

34. Basic strength order
 $(\text{CH}_3\text{CH}_2)_2\text{NH} > \text{CH}_3\text{CH}_2\text{NH}_2 > \text{NH}_3$
 More the number of +I groups, higher is the basic strength.

35. Since CN^- and NH_3 are strong field ligands, low spin complexes are formed.

Complex	Configuration	No. of unpaired electrons
$[\text{V}(\text{CN})_6]^{4-}$	$t_{2g}^3 e_g^0$	3
$[\text{Cr}(\text{NH}_3)_6]^{2+}$	$t_{2g}^4 e_g^0$	2
$[\text{Ru}(\text{NH}_3)_6]^{3+}$	$t_{2g}^5 e_g^0$	1
$[\text{Fe}(\text{CN})_6]^{4-}$	$t_{2g}^6 e_g^0$	0

Magnetic moment is directly proportional to number of unpaired electrons.

- 36.

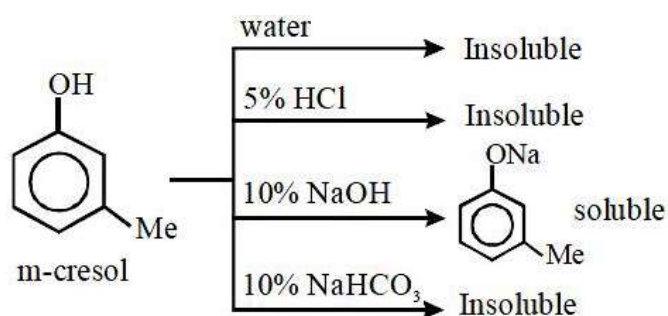

Oleic acid is also soluble in NaHCO_3

o-toluidine is not soluble in NaOH as well as NaHCO_3

Benzamide is also not soluble in NaOH & NaHCO_3

\therefore m-cresol is the right answer.

37. $\text{B}_2\text{H}_6 + 3\text{H}_2\text{O} \longrightarrow 2\text{H}_3\text{BO}_3 + 3\text{H}_2$

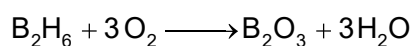

38. $\text{Sm}^{3+}(4f^5)$ = yellow colour, other ions have stable electron configurations with half filled or full-filled electron configuration.

39.

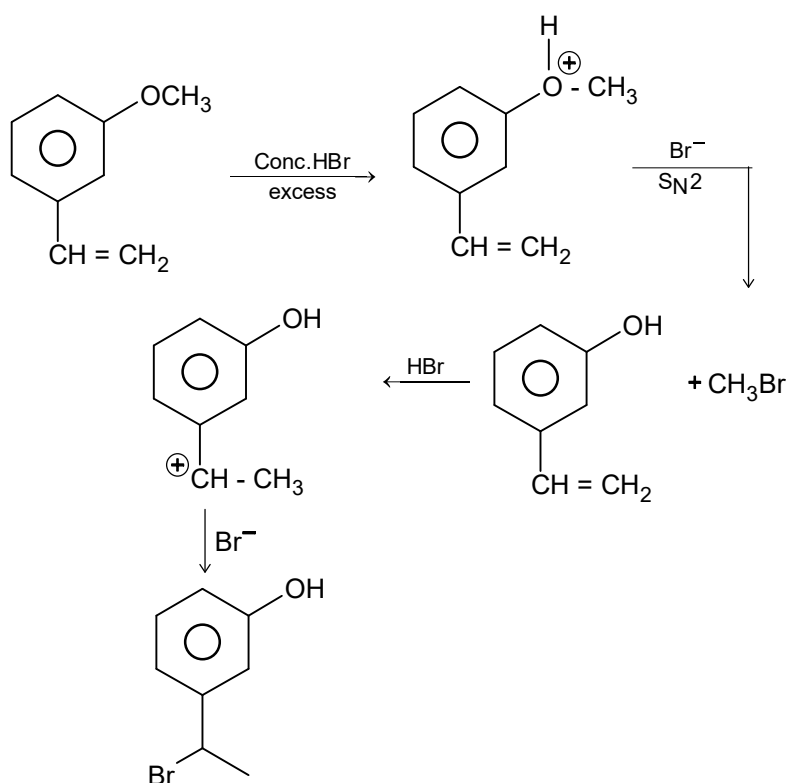

40. $n_{\text{eq.}} \text{CaCO}_3 = n_{\text{eq.}} \text{Ca(HCO}_3)_2 + n_{\text{eq.}} \text{Mg(HCO}_3)_2$ ($n_{\text{eq.}}$ = Number of equivalent)

$$\text{or, } \frac{W}{100} \times 2 = \frac{0.81}{162} \times 2 + \frac{0.73}{146} \times 2$$

$$\therefore w = 1.0$$

Volume of water = 100 mL

Mass of water = 100 g

$$\therefore \text{Hardness} = \frac{1.0}{100} \times 10^6 = 10000 \text{ ppm}$$

41.

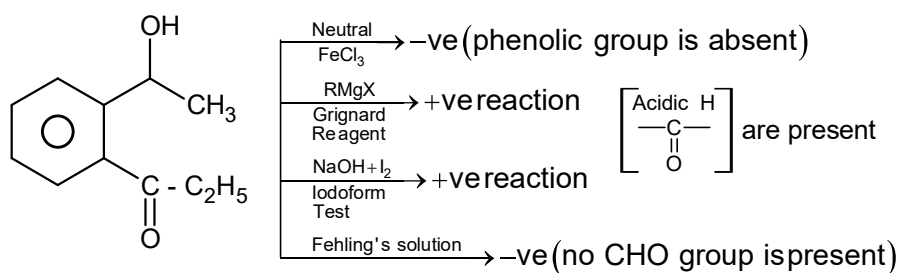

42.

$$r = K[A]^x [B]^y$$

$$0.045 = K(0.05)^x (0.05)^y \quad \dots (1)$$

$$0.090 = K(0.10)^x (0.05)^y \quad \dots (2)$$

$$0.72 = K(0.20)^x (0.10)^y \quad \dots (3)$$

Dividing (1) by (2) we get

$$\frac{0.045}{0.090} = \left(\frac{0.05}{0.10} \right)^x \Rightarrow x = 1$$

Dividing (2) by (3)

$$\frac{0.090}{0.720} = \left(\frac{0.10}{0.20}\right)^x \left(\frac{0.05}{0.10}\right)^y \Rightarrow y = 2$$

Hence, $r = K[A][B]^2$

43.

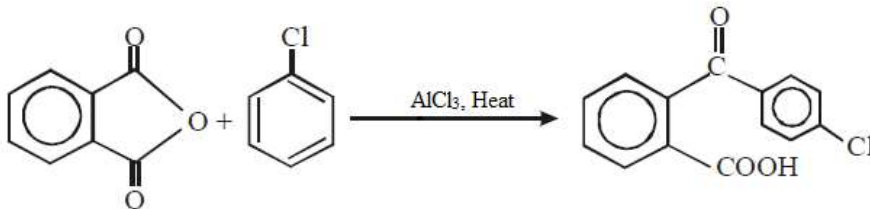

Fridel-craft acylation. -Cl group is an ortho & para directing

44. Plastics are non-biodegradable.

45.

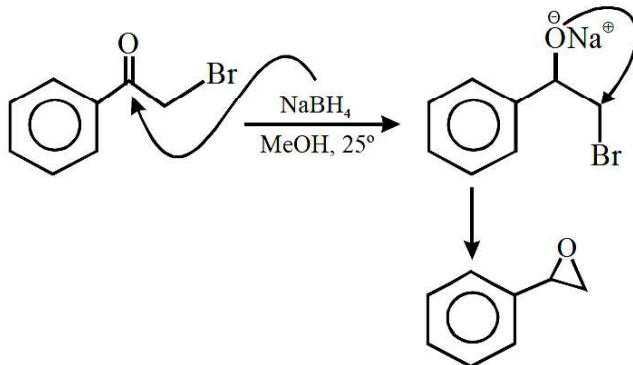

Reduction followed by substitution reaction

46.
$$\Delta H = n \int_{T_1}^{T_2} C_{p,m} dT = 3 \times \int_{300}^{1000} (23 + 0.01T) dT$$

$$= 3[23(1000 - 300)] + \frac{0.01}{2} [(1000)^2 - (300)^2]$$

$$= 61950 \text{ J} \approx 62 \text{ kJ}$$

47. Hydration enthalpy depends upon ionic potential (charge/size). As ionic potential increases hydration enthalpy increases.

$$\Delta_{\text{hyd}} H^0 \propto \frac{q}{r}$$

48.
$$\frac{x}{m} = Kp^{1/n}$$

Taking log from both sides

$$\therefore \log \frac{x}{m} = \log K + \frac{1}{n} \log P$$

$$\text{slope} = \frac{1}{n} = \frac{2}{3}$$

$$\therefore \frac{x}{m} = K p^{2/3}$$

49. $P_{\text{total}} = X_A P_A^0 + X_B P_B^0 = 0.5 \times 400 + 0.5 \times 600 = 500 \text{ mmHg}$

Now, mole fraction of A in vapour

$$Y_A = \frac{P_A}{P_{\text{total}}} = \frac{0.5 \times 400}{500} = 0.4 \text{ and mole fraction of B in vapour}$$

$$Y_B = 1 - 0.4 = 0.6$$

50. For strongest oxidising agent, standard reduction potential should be highest. Peroxy oxygen ($-\text{O}-\text{O}-$) is reduced to oxide (O^{2-}) in the change

51. According to Aufbau principle, the energy sequence is $3p < 3d < 4p < 4d$



$$3\text{S M} \quad 4\text{S M}$$

$$K_{\text{sp}} = [\text{Zr}^{4+}]^3 [\text{PO}_4^{3-}]^4 = (3\text{S})^3 \cdot (4\text{S})^4 = 6912 \text{ S}^7$$

$$\therefore \text{S} = \left(\frac{K_{\text{sp}}}{6912} \right)^{1/7}$$

53. Gabriel phthalimide synthesis:

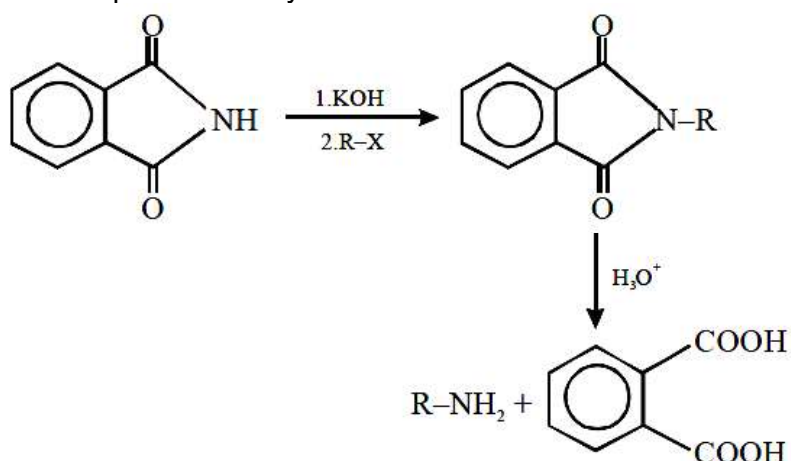

For branched chain RX, elimination reaction takes place.

54. According to the first law of thermodynamics $q = \Delta U - w$
 For cyclic process : $\Delta U = 0 \Rightarrow q = -w$
 For isothermal process : $\Delta U = 0 \Rightarrow q = -w$
 For adiabatic process : $q = 0 \Rightarrow \Delta U = W$
 For isochoric process : $w = 0 \Rightarrow \Delta U = q$

55. Both nitrogen & oxygen are donating atoms.

56. The priority of COOH is higher than OH.
 \therefore COOH is the functional group.

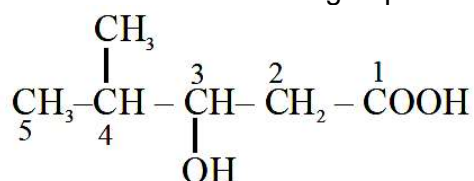

3-Hydroxy-4-methylpentanoic acid

57. n-factors of $\text{KMnO}_4 = 5$, n-factor of $\text{FeSO}_4 = 1$
 n-factors of $\text{FeC}_2\text{O}_4 = 3$, $\text{Fe}_2(\text{SO}_4)_3$ does not react
 n-factors of $\text{Fe}_2(\text{C}_2\text{O}_4)_3 = 6$,
 $n_{\text{eq}} \text{KMnO}_4 = n_{\text{eq}}[\text{FeC}_2\text{O}_4 + \text{Fe}_2(\text{C}_2\text{O}_4)_3 + \text{FeSO}_4]$
 or, $x \times 5 = 1 \times 3 + 1 \times 6 + 1 \times 1$
 $x = 2$

58. The upper stratosphere consists of ozone (O_3), which protect us from harmful ultraviolet (UV) radiations coming from sun. The layer get depleted by CFC's

59.

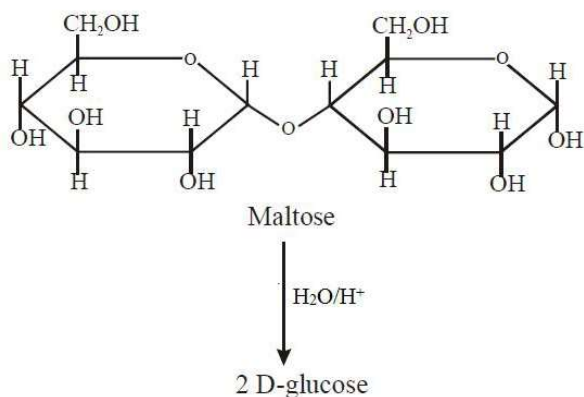

60. Ellingham diagram which are the curves of the graph between ΔG and T helps in predicting the feasibility of thermal reduction of ores.

PART C – MATHEMATICS

61. Vector perpendicular to plane containing the vectors $\hat{i} + \hat{j} + \hat{k}$ & $\hat{i} + 2\hat{j} + 3\hat{k}$ is parallel to vector

$$= \begin{vmatrix} \hat{i} & \hat{j} & \hat{k} \\ 1 & 1 & 1 \\ 1 & 2 & 3 \end{vmatrix} = \hat{i} - 2\hat{j} + \hat{k}$$

∴ Required magnitude of projection

$$= \frac{|(2\hat{i} + 3\hat{j} + \hat{k}) \cdot (\hat{i} - 2\hat{j} + \hat{k})|}{|\hat{i} - 2\hat{j} + \hat{k}|}$$

$$= \frac{|2 - 6 + 1|}{\sqrt{6}} = \frac{3}{\sqrt{6}} = \sqrt{\frac{3}{2}}$$

62. We have

$$2y \frac{dy}{dx} = 1 \Rightarrow \left. \frac{dy}{dx} \right|_{P(2+t^2, t)} = \frac{1}{2t} = 1$$

$$\Rightarrow t = \frac{1}{2}$$

$$\therefore P\left(\frac{9}{4}, \frac{1}{2}\right)$$

So, shortest distance

$$= \frac{\left| \frac{9}{4} - \frac{2}{4} \right|}{\sqrt{2}} = \frac{7}{4\sqrt{2}}$$

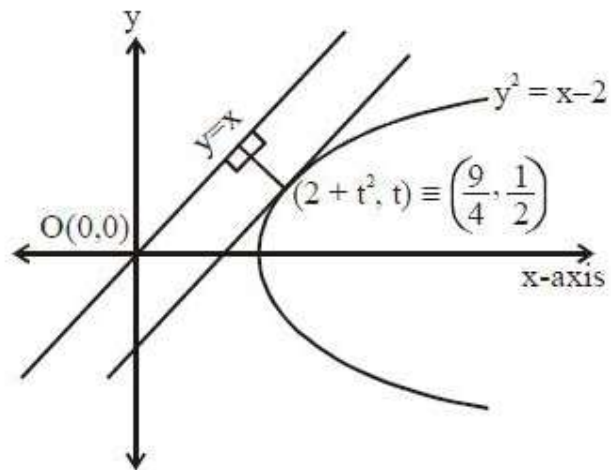

63. $(x-1)^2 + 1 = 0 \Rightarrow x = 1+i, 1-i$

$$\therefore \left(\frac{\alpha}{\beta}\right)^n = 1 \Rightarrow (\pm i)^n = 1$$

∴ n (least natural number) = 4

- 64.

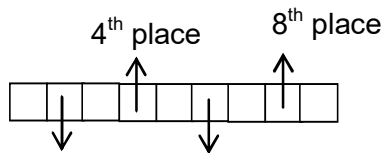

Number of such numbers = ${}^4C_3 \times \frac{3!}{2!} \times \frac{6!}{2!4!} = 180$

$$\begin{aligned}
65. \quad \int \frac{\sin \frac{5x}{2}}{\sin \frac{x}{2}} dx &= \int \frac{2 \sin \frac{5x}{2} \cos \frac{x}{2}}{2 \sin \frac{x}{2} \cos \frac{x}{2}} dx \\
&= \int \frac{\sin 3x + \sin 2x}{\sin x} dx \\
&= \int \frac{3 \sin x - 4 \sin^3 x + 2 \sin x \cos x}{\sin x} dx \\
&= \int (3 - 4 \sin^2 x + 2 \cos x) dx \\
&= \int (3 - 2(1 - \cos 2x) + 2 \cos x) dx \\
&= \int (1 + 2 \cos 2x + 2 \cos x) dx \\
&= x + \sin 2x + 2 \sin x + c
\end{aligned}$$

$$\begin{aligned}
66. \quad AP + OP + AO &= 4 \\
\sqrt{h^2 + (k-1)^2} + \sqrt{h^2 + k^2} + 1 &= 4 \\
\sqrt{h^2 + (k-1)^2} + \sqrt{h^2 + k^2} &= 3 \\
h^2 + (k-1)^2 &= 9 + h^2 + k^2 - 6\sqrt{h^2 + k^2} \\
-2k - 8 &= -6\sqrt{h^2 + k^2} \\
k + 4 &= 3\sqrt{h^2 + k^2} \\
k^2 + 16 + 8k &= 9(h^2 + k^2) \\
9h^2 + 8k^2 - 8k - 16 &= 0 \\
\text{Locus of P is } 9x^2 + 8y^2 - 8y - 16 &= 0
\end{aligned}$$

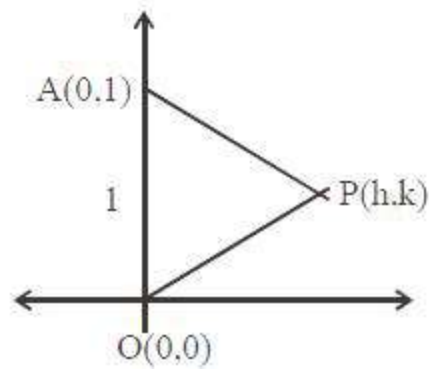

$$\begin{aligned}
67. \quad 0 < \alpha + \beta &= \frac{\pi}{2} \quad \text{and} \quad \frac{-\pi}{4} < \alpha - \beta < \frac{\pi}{4} \\
\text{If } \cos(\alpha + \beta) &= \frac{3}{5} \quad \text{then} \quad \tan(\alpha + \beta) = \frac{4}{3} \quad \text{and if } \sin(\alpha - \beta) = \frac{5}{13} \quad \text{then} \quad \tan(\alpha - \beta) = \frac{5}{12} \\
\text{(since } \alpha - \beta \text{ here lies in the first quadrant)} \\
\text{Now } \tan(2\alpha) &= \tan\{(\alpha + \beta) + (\alpha - \beta)\} \\
&= \frac{\tan(\alpha + \beta) + \tan(\alpha - \beta)}{1 - \tan(\alpha + \beta) \cdot \tan(\alpha - \beta)} = \frac{\frac{4}{3} + \frac{5}{12}}{1 - \frac{4}{3} \cdot \frac{5}{12}} = \frac{63}{16}
\end{aligned}$$

$$\begin{aligned}
68. \quad A &= \begin{bmatrix} \cos \alpha & -\sin \alpha \\ \sin \alpha & \cos \alpha \end{bmatrix} \\
A^2 &= \begin{bmatrix} \cos \alpha & -\sin \alpha \\ \sin \alpha & \cos \alpha \end{bmatrix} \begin{bmatrix} \cos \alpha & -\sin \alpha \\ \sin \alpha & \cos \alpha \end{bmatrix}
\end{aligned}$$

$$\begin{aligned}
&= \begin{bmatrix} \cos 2\alpha & -\sin 2\alpha \\ \sin 2\alpha & \cos 2\alpha \end{bmatrix} \\
A^3 &= \begin{bmatrix} \cos 2\alpha & -\sin 2\alpha \\ \sin 2\alpha & \cos 2\alpha \end{bmatrix} \begin{bmatrix} \cos \alpha & -\sin \alpha \\ \sin \alpha & \cos \alpha \end{bmatrix} \\
&= \begin{bmatrix} \cos 3\alpha & -\sin 3\alpha \\ \sin 3\alpha & \cos 3\alpha \end{bmatrix} \\
\text{Similarly } A^{32} &= \begin{bmatrix} \cos 32\alpha & -\sin 32\alpha \\ \sin 32\alpha & \cos 32\alpha \end{bmatrix} = \begin{bmatrix} 0 & -1 \\ 1 & 0 \end{bmatrix} \\
\Rightarrow \cos 32\alpha &= 0 \text{ and } \sin 32\alpha = 1 \\
\Rightarrow 32\alpha &= (4n+1)\frac{\pi}{2}, n \in I \\
\alpha &= (4n+1)\frac{\pi}{64}, n \in I \\
\alpha &= \frac{\pi}{64} \text{ for } n=0
\end{aligned}$$

69. $f(x) = \log_e \left(\frac{1-x}{1+x} \right), |x| < 1$

$$\begin{aligned}
f\left(\frac{2x}{1+x^2}\right) &= \ln \left(\frac{1 - \frac{2x}{1+x^2}}{1 + \frac{2x}{1+x^2}} \right) \\
&= \ln \left(\frac{(x-1)^2}{(x+1)^2} \right) = 2 \ln \left| \frac{1-x}{1+x} \right| = 2f(x)
\end{aligned}$$

70. Consider $\cot^{-1} \left(\frac{\frac{\sqrt{3}}{2} \cos x + \frac{1}{2} \sin x}{\frac{1}{2} \sin x - \frac{\sqrt{3}}{2} \cos x} \right)$

$$\begin{aligned}
&= \cot^{-1} \left(\frac{\sin \left(x + \frac{\pi}{3} \right)}{\cos \left(x + \frac{\pi}{3} \right)} \right) \\
&= \cot^{-1} \left(\tan \left(x + \frac{\pi}{3} \right) \right) = \frac{\pi}{2} - \tan^{-1} \left(\tan \left(x + \frac{\pi}{3} \right) \right) \\
&\begin{cases} \frac{\pi}{2} - \left(x + \frac{\pi}{3} \right) = \left(\frac{\pi}{6} - x \right); 0 < x < \frac{\pi}{6} \\ \frac{\pi}{2} - \left(\left(x - \frac{\pi}{3} \right) - \pi \right) = \left(\frac{7\pi}{6} - x \right); \frac{\pi}{6} < x < \frac{\pi}{2} \end{cases}
\end{aligned}$$

$$\therefore 2y = \begin{cases} \left(\frac{\pi}{6} - x\right)^2; & 0 < x < \frac{\pi}{6} \\ \left(\frac{7\pi}{6} - x\right)^2; & \frac{\pi}{6} < x < \frac{\pi}{2} \end{cases}$$

$$\therefore 2 \frac{dy}{dx} = \begin{cases} 2\left(\frac{\pi}{6} - x\right) \cdot (-1); & 0 < x < \frac{\pi}{6} \\ 2\left(\frac{7\pi}{6} - x\right) \cdot (-1); & \frac{\pi}{6} < x < \frac{\pi}{2} \end{cases}$$

71. $|\sqrt{x} - 2| + \sqrt{x}(\sqrt{x} - 4) + 2 = 0$
 $|\sqrt{x} - 2| + (\sqrt{x})^2 - 4\sqrt{x} + 2 = 0$
 $|\sqrt{x} - 2|^2 + |\sqrt{x} - 2| - 2 = 0$
 $|\sqrt{x} - 2| = -2$ (not possible) or $|\sqrt{x} - 2| = 1$
 $\sqrt{x} - 2 = 1, -1$
 $\sqrt{x} = 3, 1$
 $x = 9, 1$
Sum = 10

72.
$$\lim_{x \rightarrow 0} \frac{\left(\frac{\sin^2 x}{x^2}\right)(\sqrt{2} + \sqrt{1 + \cos x})}{\left(\frac{1 - \cos x}{x^2}\right)}$$

$$= \frac{(1)^2 \cdot (2\sqrt{2})}{\frac{1}{2}} = 4\sqrt{2}$$

73. $2 \cdot {}^{20}C_0 + 5 \cdot {}^{20}C_1 + 8 \cdot {}^{20}C_2 + 11 \cdot {}^{20}C_3 + \dots + 62 \cdot {}^{20}C_{20}$

$$= \sum_{r=0}^{20} (3r + 2) {}^{20}C_r$$

$$= 3 \sum_{r=0}^{20} r \cdot {}^{20}C_r + 2 \sum_{r=0}^{20} {}^{20}C_r$$

$$= 3 \sum_{r=0}^{20} r \binom{20}{r} + 2 \cdot 2^{20}$$

$$= 60 \cdot 2^{19} + 2 \cdot 2^{20} = 2^{25}$$

74. $\frac{dy}{dx} + \left(\frac{2x}{x^2 + 1}\right)y = \frac{1}{(x^2 + 1)^2}$
(Linear differential equation)

$$\therefore \text{I.F.} = e^{\int n(x^2+1)} = (x^2 + 1)$$

So, general solution is $y.(x^2 + 1) = \tan^{-1} x + c$

$$\text{As } y(0) = 0 \Rightarrow c = 0$$

$$\therefore y(x) = \frac{\tan^{-1} x}{x^2 + 1}$$

$$\text{As, } \sqrt{a}.y(1) = \frac{\pi}{32}$$

$$\Rightarrow \sqrt{a} = \frac{1}{4} \Rightarrow a = \frac{1}{16}$$

$$75. \quad g(f(x)) = \ln(f(x)) = \ln\left(\frac{2 - x \cdot \cos x}{2 + x \cdot \cos x}\right)$$

$$\therefore I = \int_0^{\pi/4} \left(\ln\left(\frac{2 - x \cdot \cos x}{2 + x \cdot \cos x}\right) + \ln\left(\frac{2 + x \cdot \cos x}{2 - x \cdot \cos x}\right) \right) dx$$

$$= \int_0^{\pi/2} (0) dx = 0 = \log_e (1)$$

76. Required Area

$$= \int_0^1 (x^2 + 3x) dx + \text{Area of}$$

rectangle PQRS

$$= \frac{11}{6} + 8 = \frac{59}{6}$$

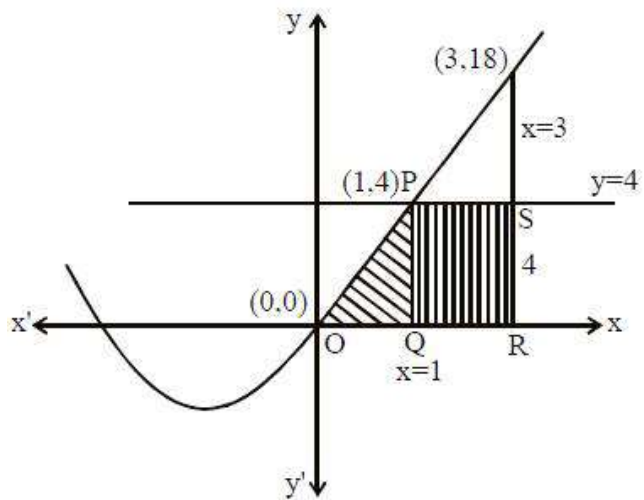

77. Let 7 observations be $x_1, x_2, x_3, x_4, x_5, x_6, x_7$

$$\bar{x} = 8 \Rightarrow \sum_{i=1}^7 x_i = 56 \quad \dots\dots\dots(1)$$

Also $\sigma^2 = 16$

$$\Rightarrow 16 = \frac{1}{7} \left(\sum_{i=1}^7 x_i^2 \right) - (\bar{x})^2$$

$$\Rightarrow 16 = \frac{1}{7} \left(\sum_{i=1}^7 x_i^2 \right) - 64$$

$$\Rightarrow \left(\sum_{i=1}^7 x_i^2 \right) = 560 \quad \dots\dots\dots(2)$$

Now, $x_1 = 2, x_2 = 4, x_3 = 10, x_4 = 12, x_5 = 14$

$$\Rightarrow x_6 + x_7 = 14, \text{ (from (1)) and } x_6^2 + x_7^2 = 100 \text{ (from (2))}$$

$$\therefore x_6^2 + x_7^2 = (x_6 + x_7)^2 - 2x_6x_7 \Rightarrow x_6x_7 = 48$$

78. Now, $\overline{MP} \cdot (10\hat{i} - 7\hat{j} + \hat{k}) = 0$

$$\Rightarrow \lambda = \frac{1}{2}$$

\therefore Length of perpendicular

$$(\text{= PM}) = \sqrt{0 + \frac{1}{4} + \frac{49}{4}}$$

$$= \sqrt{\frac{50}{4}} = \sqrt{\frac{25}{4}} = \frac{5}{\sqrt{2}},$$

which is greater than 3 but less than 4.

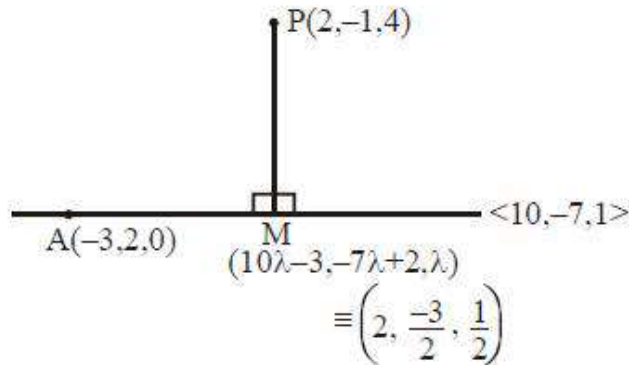

79. The contrapositive of a statement $p \rightarrow q$ is $\sim q \rightarrow \sim p$

Here, p : you are born in India

q : you are citizen of India

So, contrapositive of above statement is "If you are not a citizen of India, then you are not born in India".

80. S_A = sum of numbers between 100 and 200 which are divisible by 7.

$$\Rightarrow S_A = 105 + 112 + \dots + 196$$

$$S_A = \frac{14}{2} [105 + 196] = 2107$$

S_B = Sum of numbers between 100 and 200 which are divisible by 13.

$$S_B = 104 + 117 + \dots + 195 = \frac{8}{2} [104 + 195] = 1196$$

S_C = Sum of numbers between 100 and 200 which are divisible by 7 and 13.

$$S_C = 182$$

$$\Rightarrow \text{H.C.F. } (91, n) > 1 = S_A + S_B - S_C = 3121$$

81. $f(x) = 9x^4 + 12x^3 - 36x^2 + 25$

$$f'(x) = 36x^3 + 36x^2 - 72x$$

$$= 36x(x^2 + x - 2)$$

$$= 36x(x - 1)(x + 2)$$

$$\text{Point of minima} = \{-2, 1\} = S_1$$

$$\text{Point of maxima} = \{0\} = S_2$$

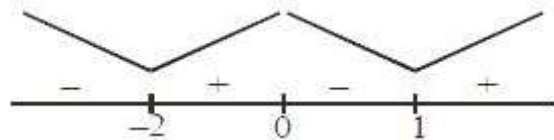

82. $(x + \sqrt{x^3 - 1})^6 + (x - \sqrt{x^3 - 1})^6$

$$= 2 \left[{}^6C_0 x^6 + {}^6C_2 x^4 (x^3 - 1) + {}^6C_4 x^2 (x^3 - 1)^2 + {}^6C_6 (x^3 - 1)^3 \right]$$

$$= 2 \left[{}^6C_0 x^6 + {}^6C_2 x^7 - {}^6C_2 x^4 + {}^6C_4 x^8 + {}^6C_4 x^2 - 2 {}^6C_4 x^5 + (x^9 - 1 - 3x^6 + 3x^3) \right]$$

\Rightarrow Sum of coefficient of even powers of x

$$= 2[1 - 15 + 15 + 15 - 1 - 3] = 24$$

83. Now, $\left| \frac{15-3t}{5} \right| = |t|$

$$\Rightarrow \frac{15-3t}{5} = t \text{ or } \frac{15-3t}{5} = -t$$

$$\therefore t = \frac{15}{8} \text{ or } t = \frac{-15}{2}$$

So, $P\left(\frac{15}{8}, \frac{15}{8}\right) \in 1^{\text{st}} \text{ quadrant}$

or $P\left(\frac{-15}{2}, \frac{15}{2}\right) \in \text{II}^{\text{nd}} \text{ Quadrant}$

84. $4a^2 + b^2 = 8 \dots\dots\dots(1)$

$$\left. \frac{dy}{dx} \right)_{(1,2)} = -\frac{4x}{y} = -2$$

$$\Rightarrow -\frac{4a}{b} = \frac{1}{2}$$

$$b = -8a$$

$$\Rightarrow b^2 = 64a^2$$

$$68a^2 = 8, a^2 = \frac{2}{17}$$

85. $\cos \alpha = \frac{3}{5}, \tan \beta = \frac{1}{3}$

$$\Rightarrow \tan \alpha = \frac{4}{3}$$

$$\Rightarrow \tan(\alpha - \beta) = \frac{\frac{4}{3} - \frac{1}{3}}{1 + \frac{4}{3} \cdot \frac{1}{3}} = \frac{9}{13}$$

$$\Rightarrow \sin(\alpha - \beta) = \frac{9}{5\sqrt{10}}$$

$$\Rightarrow \alpha - \beta = \sin^{-1}\left(\frac{9}{5\sqrt{10}}\right)$$

86. The required plane is $(2x - y - 4) + \lambda(y + 2z - 4) = 0$ it passes through $(1, 1, 0)$

$$\Rightarrow (2 - 1 - 4) + \lambda(1 - 4) = 0$$

$$\Rightarrow -3 - 3\lambda = 0 \Rightarrow \lambda = -1$$

$$\Rightarrow x - y - z = 0$$

87. $p = \frac{n}{\sqrt{2}}$, but $\frac{n}{\sqrt{2}} < 4 \Rightarrow n = 1, 2, 3, 4, 5$

Length of chord AB = $2\sqrt{16 - \frac{n^2}{2}}$

= $\sqrt{64 - 2n^2} = \ell$ (say)

For $n = 1, \ell^2 = 62$

$n = 2, \ell^2 = 56$

$n = 3, \ell^2 = 46$

$n = 4, \ell^2 = 32$

$n = 5, \ell^2 = 14$

\therefore Required sum

= $62 + 56 + 46 + 32 + 14 = 210$

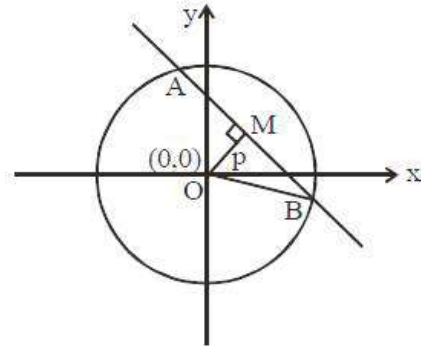

88. For non-trivial solution

$D = 0$

$$\begin{vmatrix} 1 & -c & -c \\ c & -1 & c \\ c & c & -1 \end{vmatrix} = 0 \Rightarrow 2c^3 + 3c^2 - 1 = 0$$

$\Rightarrow (c + 1)^2 (2c - 1) = 0$

\therefore Greatest value of c is $\frac{1}{2}$

89. $\phi(x) = f(x) + f(2 - x)$

$\phi'(x) = f'(x) - f'(2 - x)$ (1)

Since $f''(x) > 0$

$\Rightarrow f(x)$ is increasing $\forall x \in (0, 2)$

Case - I : When $x > 2 - x \Rightarrow x > 1$

$\Rightarrow \phi'(x) > 0 \forall x \in (1, 2)$

$\therefore \phi(x)$ is increasing on $(1, 2)$

Case - II : When $x < 2 - x \Rightarrow x < 1$

$\Rightarrow \phi'(x) < 0 \forall x \in (0, 1)$

$\therefore \phi(x)$ is decreasing on $(0, 1)$

90. $P(A|B) = \frac{P(A \cap B)}{P(B)} = \frac{P(A)}{P(B)}$

(as $A \subset B \Rightarrow P(A \cap B) = P(A)$)

$\Rightarrow P(A|B) \geq P(A)$