

## PART - A (PHYSICS)

1. A solid sphere and solid cylinder of identical radii approach an incline with the same linear velocity (see figure). Both roll without slipping all throughout. The two climb maximum heights  $h_{\text{sph}}$  and  $h_{\text{cyl}}$  on the incline. The ratio  $\frac{h_{\text{sph}}}{h_{\text{cyl}}}$  is given by:

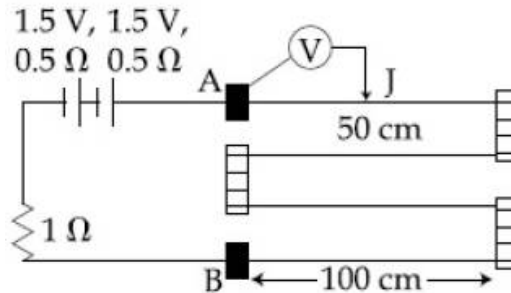

- (A) 1  
(B)  $\frac{4}{5}$   
(C)  $\frac{2}{\sqrt{5}}$   
(D)  $\frac{14}{15}$
2. In the circuit shown, a four wire potentiometer is made of a 400 cm long wire, which extends between A and B. The resistance per unit length of the potentiometer wire is  $r = 0.01 \Omega/\text{cm}$ . If an ideal voltmeter is connected as shown with jockey J at 50 cm from end A, the expected reading of the voltmeter will be:



- (A) 0.75V  
(B) 0.20V  
(C) 0.25V  
(D) 0.50V
3. A parallel plate capacitor has  $1 \mu\text{F}$  capacitance. One of its two plates is given  $+2 \mu\text{C}$  charge and the other plate,  $+4 \mu\text{C}$  charge. The potential difference developed across the capacitor is:
- (A) 3V  
(B) 1V  
(C) 5V  
(D) 2V
4. If Surface tension (S), Moment of Inertia (I) and Planck's constant (h), were to be taken as the fundamental units, the dimensional formula for linear momentum would be:
- (A)  $S^1 I^2 h^0$   
(B)  $S^1 I^2 h^{-1}$   
(C)  $S^3 I^1 h^0$   
(D)  $S^1 I^1 h^{-1}$

5. Two magnetic dipoles X and Y are placed at a separation  $d$ , with their axes perpendicular to each other. The dipole moment of Y is twice that of X. A particle of charge  $q$  is passing through their mid-point P, at angle  $\theta = 45^\circ$  with the horizontal line as shown in the figure. What would be the magnitude of force on the particle at that instant? ( $d$  is much larger than the dimensions of the dipole)

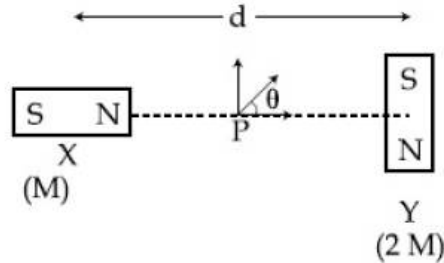

- (A)  $\left(\frac{\mu_0}{4\pi}\right) \frac{M}{(d/2)^3} \times q^v$  (B) 0
- (C)  $\left(\frac{\mu_0}{4\pi}\right) \frac{2M}{(d/2)^3} \times q^v$  (D)  $\sqrt{2} \left(\frac{\mu_0}{4\pi}\right) \frac{M}{(d/2)^3} \times q^v$
6. A damped harmonic oscillator has a frequency of 5 oscillations per second. The amplitude drops to half its value for every 10 oscillations. The time it will take to drop to  $\frac{1}{1000}$  of the original amplitude is close to:
- (A) 10s (B) 100s  
(C) 50s (D) 20s
7. A convex lens (of focal length 20 cm) and a concave mirror, having their principal axes along the same lines, are kept 80 cm apart from each other. The concave mirror is to the right of the convex lens. When an object is kept at a distance of 30 cm to the left of the convex lens, its image remains at the same position even if the concave mirror is removed. The maximum distance of the object for which this concave mirror, by itself would produce a virtual image would be:
- (A) 20 cm (B) 10 cm  
(C) 30 cm (D) 20 cm
8. A cell of internal resistance  $r$  drives current through an external resistance  $R$ . The power delivered by the cell to the external resistance will be maximum when:
- (A)  $R = 0.001 r$  (B)  $R = 1000 r$   
(C)  $R = 2r$  (D)  $R = r$
9. In a simple pendulum experiment for determination of acceleration due to gravity ( $g$ ), time taken for 20 oscillations is measured by using a watch of 1 second least count. The mean value of time taken comes out to be 30s.. The length of pendulum is measured by using a meter scale of least count 1 mm and the value obtained is 55.0 cm. The percentage error in the determination of  $g$  is close to:
- (A) 0.7 % (B) 3.5%  
(C) 6.8% (D) 0.2%

10. The temperature, at which the root mean square velocity of hydrogen molecules equals their escape velocity from the earth is closest to:  
 [Boltzmann's Constant  $k_B = 1.38 \times 10^{-23} \text{ J/K}$   
 Avogadro number  $N_A = 6.02 \times 10^{26} / \text{kg}$   
 Radius of Earth:  $6.4 \times 10^6 \text{ m}$   
 Gravitation acceleration on Earth =  $10 \text{ ms}^{-2}$ ]  
 (A) 800k (B)  $10^4 \text{ K}$   
 (C)  $3 \times 10^5$  (D) 650 K

11. A particle starts from origin O from rest and moves with a uniform acceleration along the positive x – axis. Identify all figures that correctly represent the motion qualitatively. (a = acceleration, v = velocity, x = displacement, t = time)

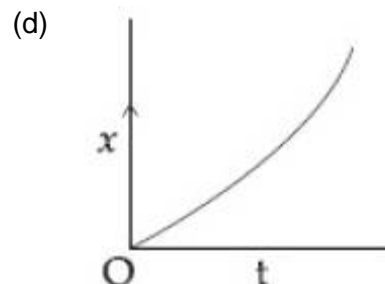
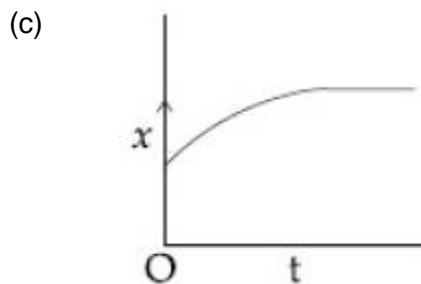
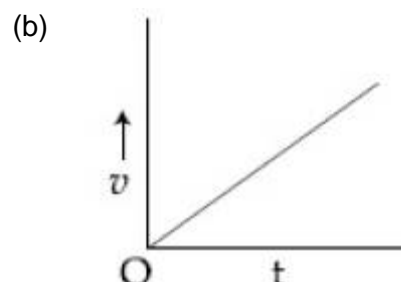
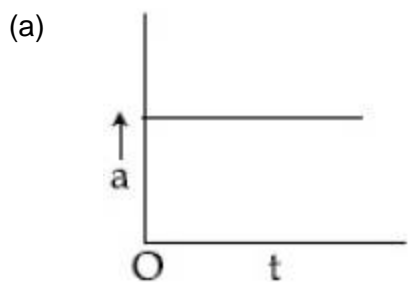

- (A) a, b, c (B) a  
 (C) b, c (D) a, b, d

12. The electric field in a region is given by  $\vec{E} = (Ax + B)\hat{i}$  where E is in  $\text{NC}^{-1}$  and x in meters. The values of constants are A = 20 SI unit and B = 10 SI unit. If the potential at x = 1 is  $V_1$  and that at x = -5 is  $V_2$  then  $V_1 - V_2$  is:  
 (A) 320 V (B) - 48 V  
 (C) - 520 V (D) 180 V

13. Young's moduli of two wires A and B are in the ratio 7 : 4. Wire A is 2 m long and has radius R. Wire B is 1.5 m long and has radius 2 mm. If the two wires stretch by the same length for a given load, then the value of R is close to:  
 (A) 1.3 mm (B) 1.5 mm  
 (C) 1.7 mm (D) 1.9 mm

14. A body of mass  $m_1$  moving with an unknown velocity of  $v_1\hat{i}$  undergoes a collinear collision with a body of mass  $m_2$  moving with a velocity  $v_2\hat{i}$ . After collision  $m_1$  and  $m_2$  move with velocities of  $v_3\hat{i}$  and  $v_4\hat{i}$  respectively.

If  $m_2 = 0.5 m_1$  and  $v_3 = 0.5 v_1$  then  $v_4$  is:

- (A)  $v_4 - \frac{v_2}{2}$  (B)  $v_4 - \frac{v_2}{4}$   
 (C)  $v_4 - v_2$  (D)  $v_4 + v_2$

15. The ratio of mass densities of nuclei of  $^{40}\text{Ca}$  and  $^{16}\text{O}$  is close to:

- (A) 0.1 (B) 5  
 (C) 2 (D) 1

16. A rectangular solid box of length 0.3 m is held horizontally, with one of its sides on the edge of a platform of height 5. When released, it slips off the table in a very short time = 0.01 s, remaining essentially horizontal. The angle by which it would rotate when it hits the ground will be (in radians) close to:

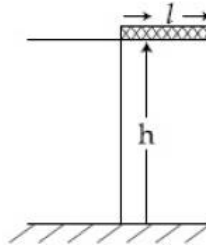

- (A) 0.5 (B) 0.6  
 (C) 0.02 (D) 0.28

17. An electric dipole is formed by two equal and opposite charges  $q$  with separation  $d$ . The charges have the same mass  $m$ . It is kept in a uniform electric field  $E$ . If it is slightly rotated from its equilibrium orientation, then its angular frequency  $\omega$  is:

- (A)  $\sqrt{\frac{qE}{2md}}$  (B)  $\sqrt{\frac{2qE}{md}}$   
 (C)  $\sqrt{\frac{qE}{md}}$  (D)  $2\sqrt{\frac{qE}{md}}$

18. The magnetic field of an electromagnetic wave is given by:

$$\vec{B} = 1.6 \times 10^{-6} \cos(2 \times 10^7 z + 6 \times 10^{15} t) (2\hat{i} + \hat{j}) \frac{\text{Wb}}{2^2}$$

The associated electric field will be:

- (A)  $\vec{E} = 4.8 \times 10^2 \cos(2 \times 10^7 z + 6 \times 10^{15} t) (-\hat{i} + 2\hat{j}) \frac{\text{V}}{\text{m}}$   
 (B)  $\vec{E} = 4.8 \times 10^2 \cos(2 \times 10^7 z + 6 \times 10^{15} t) (-2\hat{j} + 2\hat{i}) \frac{\text{V}}{\text{m}}$   
 (C)  $\vec{E} = 4.8 \times 10^2 \cos(2 \times 10^7 z + 6 \times 10^{15} t) (\hat{i} + 2\hat{j}) \frac{\text{V}}{\text{m}}$   
 (D)  $\vec{E} = 4.8 \times 10^2 \cos(2 \times 10^7 z + 6 \times 10^{15} t) (2\hat{i} + \hat{j}) \frac{\text{V}}{\text{m}}$

19. A common emitter amplifier circuit, built using an npn transistor, is shown in the figure. Its dc current gain is 250,  $R_C = 1k\Omega$  and  $V_{CC} = 10V$ . What is the minimum base current for  $V_{CE}$  to reach saturation?

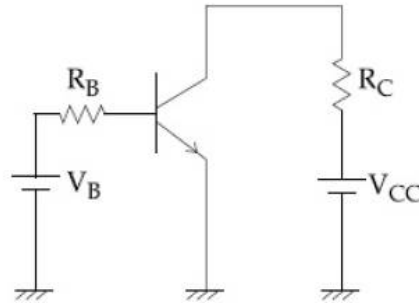

- (A)  $7\mu A$   
 (B)  $40\mu A$   
 (C)  $10\mu A$   
 (D)  $100\mu A$
20. A positive point charge is released from rest at a distance  $r_0$  from a positive line charge with uniform density. The speed ( $v$ ) of the point charge, as a function of instantaneous distance  $r$  from line charge, is proportional to

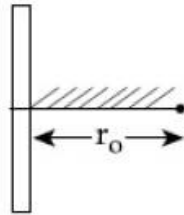

- (A)  $v \propto e^{+r/r_0}$   
 (B)  $v \propto \ln\left(\frac{r}{r_0}\right)$   
 (C)  $v \propto \sqrt{\ln\left(\frac{r}{r_0}\right)}$   
 (D)  $v \propto \left(\frac{r}{r_0}\right)$
21. Let  $|\vec{A}_1| = 3$ ,  $|\vec{A}_2| = 5$ , and  $|\vec{A}_1 + \vec{A}_2| = 5$ . The value of  $(2\vec{A}_1 + 3\vec{A}_2) \cdot (3\vec{A}_1 - 2\vec{A}_2)$  is:  
 (A)  $-106.5$   
 (B)  $-112.5$   
 (C)  $-118.5$   
 (D)  $-99.5$

22. In the figure shown, what is the current (in Ampere) drawn from the battery? You are given  
 $R_1 = 15\Omega, R_2 = 10\Omega, R_3 = 20\Omega, R_4 = 5\Omega, R_5 = 25\Omega, R_6 = 30\Omega, E = 15V$

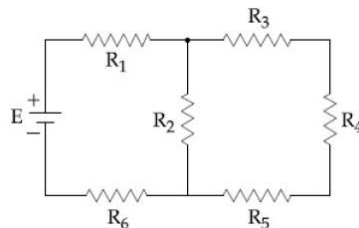

- (A)  $13/24$   
 (B)  $7/18$   
 (C)  $9/32$   
 (D)  $20/3$

23. In a line of sight radio communication, a distance of about 50 km is kept between the transmitting and receiving antennas. If the height of the receiving antenna is 70m, then the minimum height of the transmitting antenna should be: (Radius of the Earth =  $6.4 \times 10^6$  m)
- (A) 32 m (B) 40 m  
(C) 51 m (D) 20 m
24. A rocket has to be launched from each in such a way that it never returns. If E is the minimum energy delivered by the rocket launcher, what should be the minimum energy that the launcher should have if the same rocket is to be launched from the surface of the moon? Assume that the density of the earth and the moon are equal and that the earth's volume is 64 times the volume of the moon.
- (A)  $\frac{E}{32}$  (B)  $\frac{E}{16}$   
(C)  $\frac{E}{64}$  (D)  $\frac{E}{4}$
25. A circuit connected to an ac source of emf  $e = e_0 \sin(1000t)$  with t in seconds, gives a phase difference of  $\frac{\pi}{4}$  between the emf e and current i. Which of the following circuits will exhibit this?
- (A) RC circuit with  $R = 1 \text{ k}\Omega$  and  $C = 1 \mu\text{F}$  (B) RL circuit with  $R = 1 \text{ k}\Omega$  and  $L = 10 \text{ mH}$   
(C) RL circuit with  $R = 1 \text{ k}\Omega$  and  $L = 1 \text{ mH}$  (D) RC circuit with  $R = 1 \text{ k}\Omega$  and  $C = 10 \mu\text{F}$
26. A nucleus A, with a finite de – broglie wavelength  $\lambda_A$ , undergoes spontaneous fission into two nuclei B and C of equal mass. B flies in the same direction as that of A, while C flies in the opposite direction with a velocity equal to half of that of F. The de – Broglie wavelength  $\lambda_B$  and  $\lambda_C$  of B and C are respectively :
- (A)  $\lambda_A, 2\lambda_A$  (B)  $2\lambda_A, \lambda_A$   
(C)  $\lambda_A, \frac{\lambda_A}{2}$  (D)  $\frac{\lambda_A}{2}, \lambda_A$
27. Calculate the limit of resolution of a telescope objective having a diameter of 200 cm, if it has to detect light of wavelength 500 nm coming from a star.
- (A)  $457.5 \times 10^{-9}$  radian (B)  $610 \times 10^{-9}$  radian  
(C)  $305 \times 10^{-9}$  radian (D)  $152.5 \times 10^{-9}$  radian

28. Two very long, straight and insulated wires are kept at  $90^\circ$  angle from each other in  $xy$  – plane as shown in the figure.

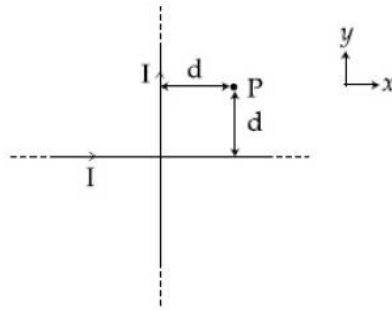

These wires carry currents of equal magnitude  $I$ , whose directions are shown in the figure. The net magnetic field at point  $P$  will be:

- (A)  $\frac{\mu_0 I}{2\pi d}(\hat{x} + \hat{y})$  (B)  $\frac{+\mu_0 I}{\pi d}(\hat{z})$   
 (C) Zero (D)  $-\frac{\mu_0 I}{2\pi d}(\hat{x} + \hat{y})$
29. The given diagram shows four processes i.e., isochoric, isothermal and adiabatic. The correct assignment of the processes, in the same order is given by:

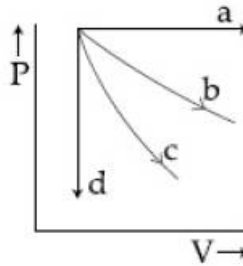

- (A) a d c b (B) a d b c  
 (C) d a c b (D) d a b c
30. A uniform rectangular thin sheet ABCD of mass  $M$  has length  $a$  and breadth  $b$ , as shown in the figure. If the shaded portion HBGO is cut off, the coordinates of the centre of mass of the remaining portion will be:

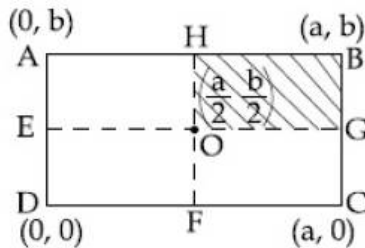

- (A)  $\left(\frac{5a}{3}, \frac{5b}{3}\right)$  (B)  $\left(\frac{2a}{3}, \frac{2b}{3}\right)$   
 (C)  $\left(\frac{3a}{4}, \frac{3b}{4}\right)$  (D)  $\left(\frac{5a}{12}, \frac{5b}{12}\right)$

## PART -B (CHEMISTRY)

31. The statement that is INCORRECT about the interstitial compound is:  
 (A) they have metallic conductivity (B) they have high melting points  
 (C) they are chemically reactive (D) they are very hard

32. The major product of the following reaction is:

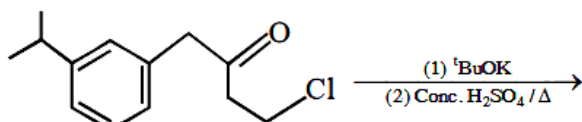

- (A)
- (B)
- (C)
- (D)

33. The major product of the following reaction is:

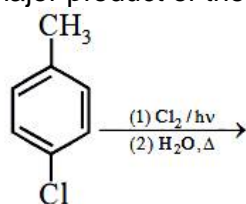

- (A)
- (B)
- (C)
- (D)

34. If  $p$  is the momentum of the fastest electron ejected from a metal surface after the irradiation of light having wavelength  $\lambda$ , then for (A)  $5p$  momentum of the photoelectron, the wavelength of the light should be:  
 (Assume kinetic energy of ejected photoelectron to be very high in comparison to work function)

- (A)  $\frac{3}{4}\lambda$  (B)  $\frac{1}{2}\lambda$   
 (C)  $\frac{4}{9}\lambda$  (D)  $\frac{2}{3}\lambda$



35. The ion that has  $sp^3d^2$  hybridization for the central atom is:

- (A)  $[IF_6]^-$  (B)  $[ICl_4]^-$   
 (C)  $[ICl_2]^-$  (D)  $[BrF_2]^-$

36. The major product obtained in the following reaction is:

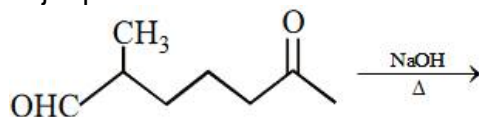

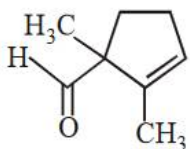
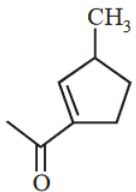
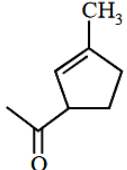
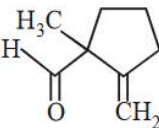
- (A)  (B)   
 (C)  (D) 

37. For a reaction scheme.  $A \xrightarrow{k_1} B \xrightarrow{k_2} C$  if the rate of formation of B is set to be zero then the concentration of B is given by

- (A)  $\left(\frac{k_1}{k_2}\right)[A]$  (B)  $(k_1 - k_2)[A]$   
 (C)  $k_1 k_2 [A]$  (D)  $(k_1 + k_2)[A]$

38. For the following reactions, equilibrium constants are given:

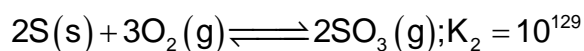
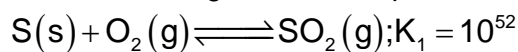

The equilibrium constant for the reaction  $2SO_2(g) + O_2(g) \rightleftharpoons 2SO_3(g)$  is:

- (A)  $10^{77}$  (B)  $10^{25}$   
 (C)  $10^{181}$  (D)  $10^{154}$

39. Calculate the standard cell potential (in V) of the cell in which following reaction takes place:

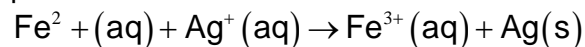

Given that:

$$E^0_{Ag^+/Ag} = xV$$

$$E^0_{Fe^{2+}/Fe} = yV$$

$$E^0_{Fe^{3+}/Fe} = zV$$

- (A)  $x - z$  (B)  $x + y - z$   
 (C)  $x - y$  (D)  $x + 2y - 3z$

40. The covalent alkaline earth metal halide ( $X = \text{Cl, Br, I}$ ) is:  
 (A)  $\text{BeX}_2$  (B)  $\text{CaX}_2$   
 (C)  $\text{SrX}_2$  (D)  $\text{MgX}_2$
41. The structure of Nylon – 6 is:  
 (A)  $\left[ (\text{CH}_2)_4 - \overset{\text{O}}{\parallel} \text{C} - \overset{\text{H}}{\text{N}} \right]_n$  (B)  $\left[ \overset{\text{O}}{\parallel} \text{C} - (\text{CH}_2)_6 - \overset{\text{H}}{\text{N}} \right]_n$   
 (C)  $\left[ \overset{\text{O}}{\parallel} \text{C} - (\text{CH}_2)_5 - \overset{\text{H}}{\text{N}} \right]_n$  (D)  $\left[ (\text{CH}_2)_6 - \overset{\text{O}}{\parallel} \text{C} - \overset{\text{H}}{\text{N}} \right]_n$
42. The IUPAC symbols for the element with atomic number 119 would be:  
 (A) uun (B) uue  
 (C) unh (D) une
43. Which of the following compounds will show the maximum 'enol' content?  
 (A)  $\text{CH}_3\text{COCH}_3$  (B)  $\text{CH}_3\text{COCH}_2\text{CONH}_2$   
 (C)  $\text{CH}_3\text{COCH}_2\text{COCH}_3$  (D)  $\text{CH}_3\text{COCH}_2\text{COOC}_2\text{H}_5$
44. 0.27 g of a long chain fatty acid was dissolved in  $100 \text{ cm}^3$  of hexane. 10 mL of this solution was added dropwise to the surface of water in a round watch glass. Hexane evaporates and a monolayer is formed. The distance from edge to centre of the watch glass is 10 cm. What is the height of the monolayer?  
 [Density of fatty acid =  $0.9 \text{ g cm}^{-3}$ ,  $\pi = 3$ ]  
 (A)  $10^{-4} \text{ m}$  (B)  $10^{-8} \text{ m}$   
 (C)  $10^{-2} \text{ m}$  (D)  $10^{-6} \text{ m}$
45. The percentage composition of carbon by mole in methane is:  
 (A) 80% (B) 20%  
 (C) 75% (D) 25%
46. The Mond process is used for the:  
 (A) Extraction of Mo (B) Extraction of Zn  
 (C) Purification of Zr and Ti (D) Purification of Ni
47. Which one of the following alkenes when treated with HCl yields majorly an anti Markovnikov product?  
 (A)  $\text{H}_2\text{N} - \text{CH} = \text{CH}_2$  (B)  $\text{F}_3\text{C} - \text{CH} = \text{CH}_2$   
 (C)  $\text{CH}_3\text{O} - \text{CH} = \text{CH}_2$  (D)  $\text{Cl} - \text{CH} = \text{CH}_2$
48. 5 moles of an ideal gas at 100 K are allowed to undergo reversible compression till its temperature becomes 200 K. If  $C_V = 28 \text{ JK}^{-1} \text{ mol}^{-1}$ , calculate  $\Delta U$  and  $\Delta pV$  for this process. ( $R = 8.0 \text{ J K}^{-1} \text{ mol}^{-1}$ )  
 (A)  $\Delta U = 2.8 \text{ kJ}; \Delta(pV) = 0.8 \text{ kJ}$  (B)  $\Delta U = 14 \text{ kJ}; \Delta(pV) = 4 \text{ kJ}$   
 (C)  $\Delta U = 14 \text{ kJ}; \Delta(pV) = 18 \text{ kJ}$  (D)  $\Delta U = 14 \text{ kJ}; \Delta(pV) = 0.8 \text{ J}$

49. The calculated spin only magnetic moments (BM) of the anionic and cationic species of  $[\text{Fe}(\text{H}_2\text{O})_6]_2^-$  and  $[\text{Fe}(\text{CN})_6]^+$ , respectively, are:
- (A) 0 and 5.92 (B) 2.84 and 5.92  
(C) 0 and 4.9 (D) 4.9 and 0

50. Fructose and glucose can be distinguished by:
- (A) Benedict's test (B) Fehling's test  
(C) Barfoed's test (D) Seliwanoff's test

51. The major product in the following reaction is:

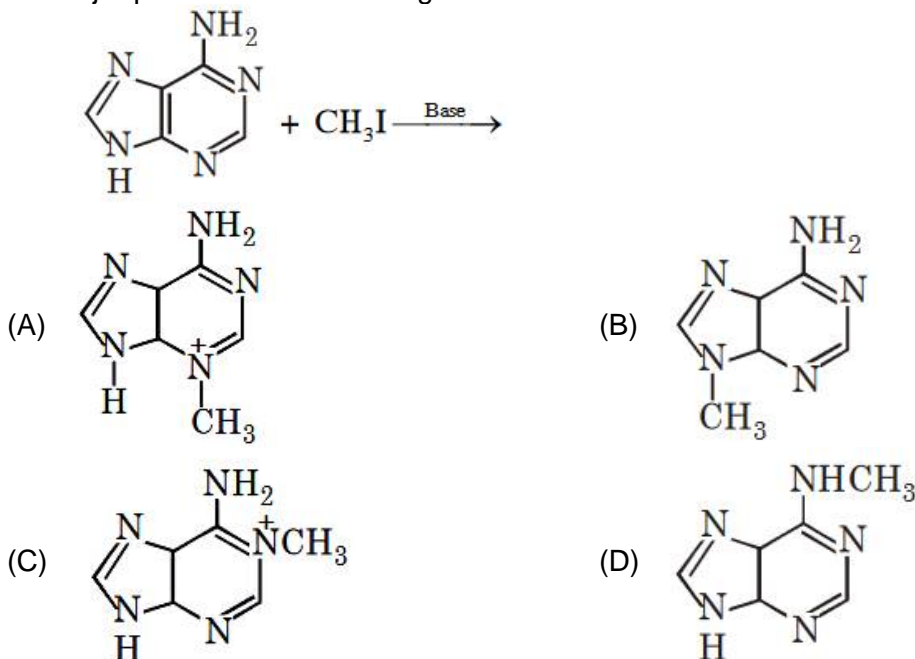

52. Polysubstitution is a major drawback in:
- (A) Friedel Craft's alkylation (B) Reimer Tiemann reaction  
(C) Acetylation of aniline (D) Friedel Craft's acylation

53. The strength of 11.2 volume solution of  $\text{H}_2\text{O}_2$  is: [Given that molar mass of H = 1 g mol<sup>-1</sup> and O = 16 g mol<sup>-1</sup>]
- (A) 3.4% (B) 1.7%  
(C) 13.6% (D) 34%

54. For the solution of the gases w, x, y and z in water at 298 K, the Henry's law constants ( $K_H$ ) are 0.5, 2.35 and 40 kbar, respectively. The correct plot for the given data is:

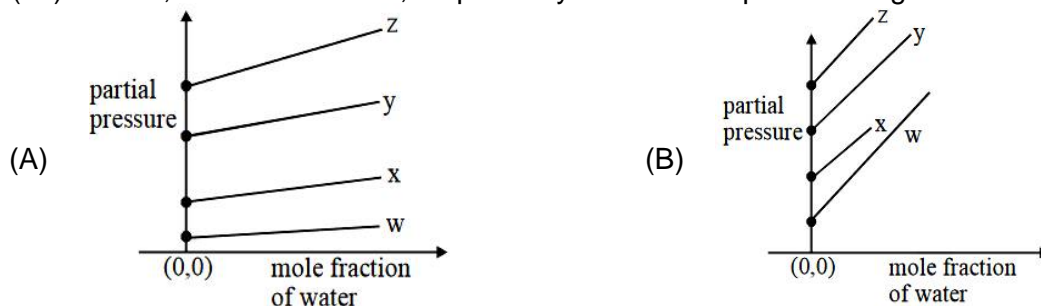

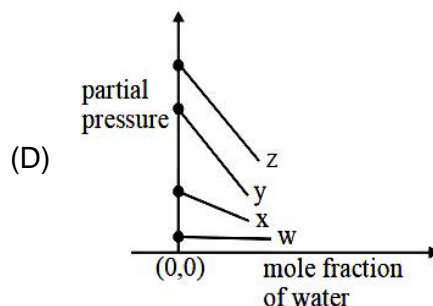
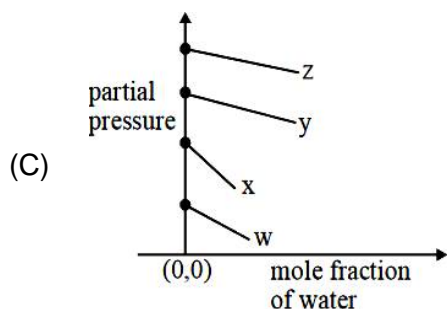

55. Among the following molecules / ions  $C_2^{2-}$ ,  $N_2^{2-}$ ,  $O_2^{2-}$ ,  $O_2$  which one is diamagnetic and has the shortest bond length?
- (A)  $O_2^{2-}$  (B)  $C_2^{2-}$   
 (C)  $O_2$  (D)  $N_2^{2-}$
56. The major product obtained in the following reactions is”

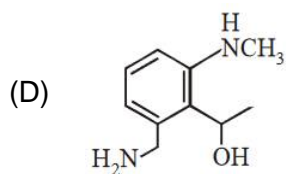
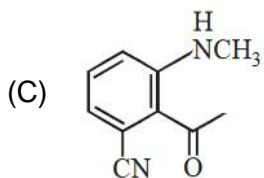
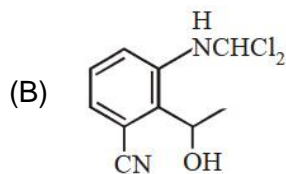
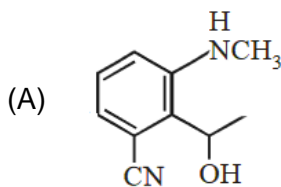
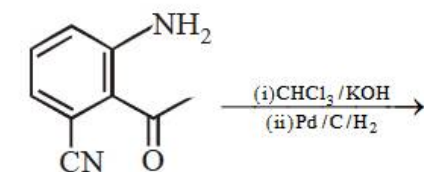

57. The maximum prescribed concentration of copper in drinking water is:
- (A) 0.5 ppm (B) 3 ppm  
 (C) 5 ppm (D) 0.05 ppm
58. The correct statement about  $ICl_5$  and  $ICl_4^-$  is:
- (A)  $ICl_5$  is trigonal bipyramidal and  $ICl_4^-$  is tetrahedral  
 (B)  $ICl_5$  is square pyramidal and  $ICl_4^-$  is square planar  
 (C)  $ICl_5$  is square pyramidal and  $ICl_4^-$  is tetrahedral  
 (D) Both are isostructural

59. The compound that inhibits the growth of tumors is:  
 (A) trans -  $[\text{Pd}(\text{Cl})_2(\text{NH}_3)_2]$  (B) trans -  $[\text{Pt}(\text{Cl})_2(\text{NH}_3)_2]$   
 (C) cis -  $[\text{Pd}(\text{Cl})_2(\text{NH}_3)_2]$  (D) cis -  $[\text{Pt}(\text{Cl})_2(\text{NH}_3)_2]$

60. Consider the bcc unit cells of the solid 1 and 2 with the position of atoms as shown below. The radius of atom B is twice that of atom A. The unit cell edge length is 50% more in solid 2 than in 1. What is the approximate packing efficiency in solid 2?

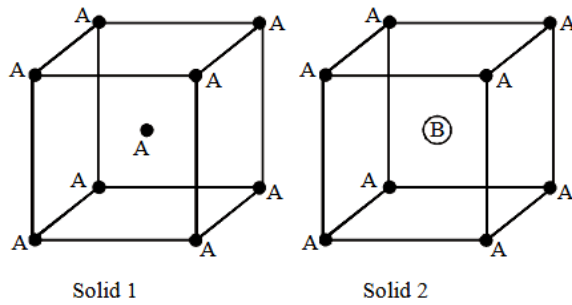

- (A) 90% (B) 75%  
 (C) 65% (D) 45%

## PART-C (MATHEMATICS)

61. Let  $S(\alpha) = \{(x, y) : y^2 \leq x, 0 \leq \alpha\}$  and  $A(\alpha)$  is area of the regions  $S(\alpha)$ . If for a  $\lambda$ ,  $0 < \lambda < 4$ ,  $A(\lambda) : A(4) = 2 : 5$  then  $\lambda$  equals:
- (A)  $4\left(\frac{2}{5}\right)^{\frac{1}{3}}$  (B)  $2\left(\frac{2}{5}\right)^{\frac{1}{3}}$   
 (C)  $4\left(\frac{4}{25}\right)^{\frac{1}{3}}$  (D)  $2\left(\frac{4}{25}\right)^{\frac{1}{3}}$
62. Let  $f(x) = \int_0^x g(t)dt$ , where  $g$  is a non zero even function. If  $f(x+5) = g(x)$ , then  $\int_0^x f(t)dt$  equals
- (A)  $\int_{x+5}^5 g(t)dt$  (B)  $2 \int_5^{x-5} g(t)dt$   
 (C)  $\int_5^{x+5} g(t)dt$  (D)  $5 \int_{x+5}^5 g(t)dt$
63. Suppose that the points  $(h, k)$ ,  $(1, 2)$  and  $(-3, 4)$  lie on the line  $L_1$ . If a line  $L_2$  passing through the points  $(h, k)$  and  $(4, 3)$  is perpendicular to  $L_1$ , then  $\frac{k}{h}$  equals:
- (A)  $-\frac{1}{7}$  (B)  $\frac{1}{3}$   
 (C) 3 (D) 0
64. Let  $f(x) = a^x$  ( $a > 0$ ) be written as  $f(x) = f_1(x) + f_2(x)$ , where  $f_1(x)$  is an even function and  $f_2(x)$  is an odd function. Then  $f_1(x+y) + f_1(x-y)$  equals
- (A)  $2f_1(x)f_2(y)$  (B)  $2f_1(x)f_1(y)$   
 (C)  $2f_1(x+y)f_2(x-y)$  (D)  $2f_1(x+y)f_1(x-y)$
65. Let  $f : [-1, 3] \rightarrow \mathbb{R}$  be defined as
- $$f(x) = \begin{cases} |x| + [x], & -1 \leq x < 1 \\ x + |x|, & 1 \leq x < 2 \\ x + |x|, & 2 \leq x \leq 3 \end{cases}$$
- where  $[t]$  denotes the greatest integer less than or equal to  $t$ . Then,  $f$  is discontinuous at:
- (A) four or more points (B) only one point  
 (C) only two points (D) only three points

$z = \frac{\sqrt{3}}{2} + \frac{i}{2}(i + \sqrt{-1})$ , then  $(1 + iz + z^5 + iz^8)^9$  is equal to:

- (A) -1  
(B) 1  
(C)  $(-1 + 2i)^9$   
(D) 0

67. Which one of the following, statements is not a tautology:

- (A)  $(p \vee q) \rightarrow (p \vee (\sim q))$   
(B)  $(p \vee q) \rightarrow p$   
(C)  $p \rightarrow (p \vee q)$   
(D)  $(p \wedge q) \rightarrow (\sim p) \vee q$

68. Given that the slope of the tangent to a curve  $y = y(x)$  at any point  $(x, y)$  is  $\frac{2y}{x^2}$ . If the curve passes through the centre of the circle  $x^2 + y^2 - 2x - 2y = 0$ , then its equation is:

- (A)  $x \log_e |y| = x - 1$   
(B)  $x \log_e |y| = -2(x - 1)$   
(C)  $x^2 \log_e |y| = -2(x - 1)$   
(D)  $x \log_e |y| = 2(x - 1)$

69. If  $f(1) = 1, f'(1) = 3$ , then the derivative of  $f(f(f(x))) + (f(x))^2$  at  $x = 1$  is:

- (A) 33  
(B) 15  
(C) 9  
(D) 12

70. The number of four – digit numbers strictly greater than 4321 that can be formed using the digits 0, 1, 2, 3, 4, 5 (repetition of digits is allowed) is:

- (A) 360  
(B) 288  
(C) 310  
(D) 306

71. If a point R  $(4, y, z)$  lies on the line segment joining the points P  $(2, -3, 4)$  and Q  $(8, 0, 10)$ , then the distance of R from the origin is:

- (A)  $\sqrt{53}$   
(B) 6  
(C)  $2\sqrt{14}$   
(D)  $2\sqrt{21}$

72. If the system of linear equations

$$x - 2y + kz = 1$$

$$2x + y + z = 2$$

$$3x - y - kz = 3$$

Has a solution  $(x, y, z) \neq 0$ , then  $(x, y)$  lies on the straight line whose equation is:

- (A)  $3x - 4y - 1 = 0$   
(B)  $4x - 3y - 4 = 0$   
(C)  $4x - 3y - 1 = 0$   
(D)  $3x - 4y - 4 = 0$

73. A student score the following marks in five tests : 45, 54, 41, 57, 43. His score is not known for the sixth test. If the mean score is 48 in the six tests, then the standard deviation of the marks in six tests is:

- (A)  $\frac{10}{3}$   
(B)  $\frac{100}{3}$   
(C)  $\frac{100}{\sqrt{3}}$   
(D)  $\frac{10}{\sqrt{3}}$

74. The vector equation of the plane through the line of intersection of the planes  $x + y + z = 1$  and  $2x + 3y + 4z = 5$  which is perpendicular to the plane  $x - y + z = 0$  is:
- (A)  $\vec{r} \times (\hat{i} - \hat{k}) + 2 = 0$  (B)  $\vec{r} \cdot (\hat{i} - \hat{k}) - 2 = 0$   
 (C)  $\vec{r} \cdot (\hat{i} - \hat{k}) + 2 = 0$  (D)  $\vec{x} \times (\hat{i} - \hat{k}) + 2 = 0$
75. If the lengths of the sides of a triangle are in A.P. and the greatest angle is double the smallest, then a ratio of lengths of the sides of this triangle:
- (A) 4:5:6 (B) 5:6:7  
 (C) 3:4:5 (D) 5:9:13
76. In an ellipse, with centre at the origin, if the difference of the lengths of major axis and minor axis is 10 and one of the foci is at  $(0, 5\sqrt{3})$ , then the length of its latus rectum is:
- (A) 6 (B) 5  
 (C) 8 (D) 10
77. The minimum number of times one has to toss a fair coin so that the probability; of observing at least one head is at least 90% is:
- (A) 2 (B) 3  
 (C) 4 (D) 5
78. If the eccentricity of the standard hyperbola passing, through the point  $(4, 6)$  is 2, then the equation of the tangent to the hyperbola at  $(4, 6)$  is:
- (A)  $2x - 3y + 10 = 0$  (B)  $x - 2y + 8 = 0$   
 (C)  $2x - y - 2 = 0$  (D)  $3x - 2y = 0$
79. The number of integral values of  $m$  for which the equation  $(1 + m^2)x^2 - 2(1 + 3m)x + (1 + 8m) = 0$  has no real root is:
- (A) infinitely many (B) 2  
 (C) 3 (D) 1
80. Then sum  $\sum_{k=1}^{20} k \frac{1}{2^k}$  is equal to:
- (A)  $2 - \frac{11}{2^{19}}$  (B)  $1 - \frac{11}{2^{20}}$   
 (C)  $2 - \frac{21}{2^{20}}$  (D)  $2 - \frac{3}{2^{17}}$
81. Let  $\vec{a} = 3\hat{i} + 2\hat{j} + x\hat{k}$  and  $\vec{b} = \hat{i} - \hat{j} + \hat{k}$ , for some real  $x$ . Then  $|\vec{a} \times \vec{b}| = r$  is possible if:
- (A)  $r \geq 5\sqrt{\frac{3}{2}}$  (B)  $3\sqrt{\frac{3}{2}} < r < 5\sqrt{\frac{3}{2}}$   
 (C)  $\sqrt{\frac{3}{2}} < r \leq 3\sqrt{\frac{3}{2}}$  (D)  $0 < r \leq \sqrt{\frac{3}{2}}$



82. Then tangent and the normal lines at the point  $(\sqrt{3}, 1)$  to the circle  $x^2 + y^2 = 4$  and the  $x$  – axis form a triangle. The area of this triangle (in square units) is:
- (A)  $\frac{1}{\sqrt{3}}$  (B)  $\frac{4}{\sqrt{3}}$   
 (C)  $\frac{1}{3}$  (D)  $\frac{2}{\sqrt{3}}$
83. The tangent to the parabola  $y^2 = 4x$  at the point where it intersects the circle  $x^2 + y^2 = 5$  in the first quadrant, passes through the point:
- (A)  $\left(-\frac{1}{3}, \frac{4}{3}\right)$  (B)  $\left(\frac{3}{4}, \frac{7}{4}\right)$   
 (C)  $\left(-\frac{1}{4}, \frac{1}{2}\right)$  (D)  $\left(\frac{1}{4}, \frac{3}{4}\right)$
84. The height of a right circular cylinder of maximum volume inscribed in a sphere of radius 3 is:
- (A)  $\sqrt{3}$  (B)  $\sqrt{6}$   
 (C)  $2\sqrt{3}$  (D)  $\frac{2}{3}\sqrt{3}$
85. Let the numbers 2, b, c be in an A.P and  $A = \begin{bmatrix} 1 & 1 & 1 \\ 2 & b & c \\ 4 & b^2 & c^2 \end{bmatrix}$ . If  $\det(A) \in [2, 16]$  then ce lies in the interval
- (A)  $[3, 2 + 2^{2/4}]$  (B)  $(2 + 2^{3/4}, 4)$   
 (C)  $\{2, 3\}$  (D)  $[4, 6]$
86. Let  $f : \mathbb{R} \rightarrow \mathbb{R}$  be a differentiable function satisfying  $f'(3) + f'(2) = 0$ . Then  $\lim_{x \rightarrow \infty} \left( \frac{1 + f(3+x) - f(3)}{1 + f(2-x) - f(2)} \right)^{\frac{1}{x}}$  is equal to:
- (A)  $e^2$  (B) 1  
 (C) e (D)  $e^{-1}$
87. If  $\int \frac{dx}{x^3(1+x^6)^{2/3}} = xf(x)(1+x^6)^{\frac{1}{3}} + C$  where C is a constant of integration, then the function  $f(x)$  is equal to:
- (A)  $-\frac{1}{2x^2}$  (B)  $-\frac{1}{2x^3}$   
 (C)  $-\frac{1}{2x^3}$  (D)  $\frac{3}{x^2}$

88. Two vertical poles of heights, 20 m and 80m stand a apart on a horizontal plane. The height (in meters) of the point of intersection of the lines joining the top of each pole to the foot of the other, from his horizontal plane is:
- (A) 18 (B) 12  
(C) 16 (D) 15

89. If the fourth term in the binomial expansion of  $\left(\sqrt{\frac{1}{x^{1+\log_{10} x}} + x^{\frac{1}{12}}}\right)^6$  is equal to 200, and  $x > 1$ , then the value of x is:
- (A)  $10^4$  (B) 100  
(C)  $10^3$  (D) 10

90. If three distinct number a, b, c are in G.P. and the equations  $ax^2 + 2bc + c = 0$  and  $dx^2 + 2ex + f = 0$  have a common root, then which one of the following statements is correct?
- (A)  $\frac{d}{a}, \frac{e}{b}, \frac{f}{c}$  are in A.P. (B) d, e, f are in A.P.  
(C)  $\frac{d}{a}, \frac{e}{b}, \frac{f}{c}$  are in G.P. (D) d, e, f are in G.P.

# HINTS AND SOLUTIONS

## PART A – PHYSICS

1. For solid sphere

$$\frac{1}{2}mv^2 + \frac{1}{2} \cdot \frac{2}{5}mR^2 \cdot \frac{v^2}{R^2} = mgh_{\text{sph}}$$

For solid cylinder

$$\frac{1}{2}mv^2 + \frac{1}{2} \cdot \frac{1}{2}mR^2 \cdot \frac{v^2}{R^2} = mgh_{\text{cyl}}$$

$$\Rightarrow \frac{h_{\text{sph}}}{h_{\text{cyl}}} = \frac{7/5}{3/2} = \frac{14}{15}$$

2. Resistance of wire AB =  $400 \times 0.01 = 4 \Omega$

$$i = \frac{3}{6} = 0.5 \text{ A}$$

Now voltmeter reading =  $i$  (Resistance of 50 cm length)

$$= (0.5 \text{ A}) (0.01 \times 50) = 0.25 \text{ volt}$$

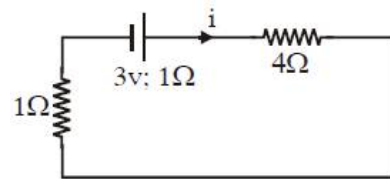

- 3.

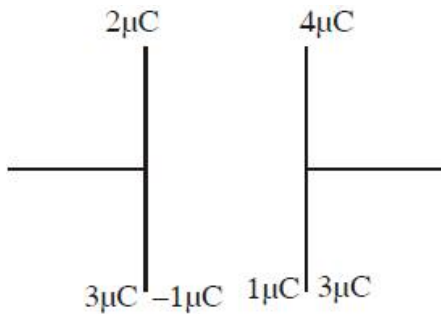

Charges at inner plates are  $1 \mu\text{C}$  and  $-1 \mu\text{C}$ .

$\therefore$  Potential difference across capacitor

$$= \frac{q}{c} = \frac{1\mu\text{C}}{1\mu\text{F}} = \frac{1 \times 10^{-6} \text{ C}}{1 \times 10^{-6} \text{ Farad}} = 1 \text{ V}$$

- 4.

$$p = k s^a l^b h^c$$

Where  $k$  is dimensionless constant

$$MLT^{-1} = (MT^{-2})^a (ML^2)^b (ML^2T^{-1})^c$$

$$a + b + c = 1$$

$$2b + 2c = 1$$

$$-2a - c = -1$$

$$a = \frac{1}{2} \quad b = \frac{1}{2} \quad c = 0$$

$$S^{1/2} l^{1/2} h^0$$

5.

$$B_1 = 2 \left( \frac{\mu_0}{4\pi} \right) \frac{M}{(d/2)^3}; \quad B_2 = \left( \frac{\mu_0}{4\pi} \right) \frac{2M}{(d/2)^3}$$

$$B_1 = B_2$$

$\Rightarrow B_{\text{net}}$  is at  $45^\circ$  ( $\theta = 45^\circ$ )

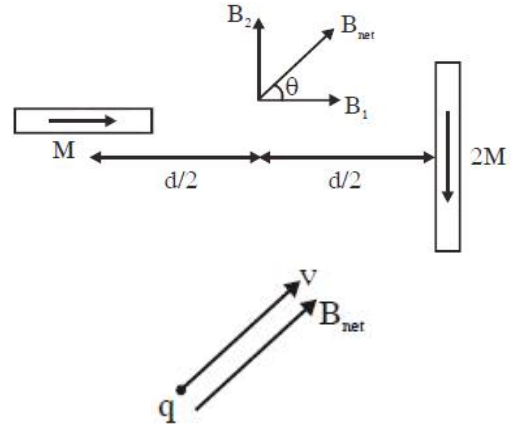

Velocity of charge and  $B_{\text{net}}$  are parallel so by

$\vec{F} = q(\vec{v} \times \vec{B})$  force on charge particle is zero.

6.

$$A = A_0 e^{-\gamma t}$$

$$A = \frac{A_0}{2} \text{ after 10 oscillations}$$

$\therefore$  After 2 seconds

$$\frac{A_0}{2} = A_0 e^{-\gamma(2)} \quad ; \quad 2 = e^{2\gamma}$$

$$\ln 2 = 2\gamma \quad ; \quad \gamma = \frac{\ln 2}{2}$$

$$\therefore A = A_0 e^{-\gamma t}$$

$$\ln \frac{A_0}{A} = \gamma t \quad ; \quad \ln 1000 = \frac{\ln 2}{2} t$$

$$2 \left( \frac{3 \ln 10}{\ln 2} \right) = t \quad ; \quad \frac{6 \ln 10}{\ln 2} = t$$

$$t = 19.931 \text{ sec}$$

$$t \approx 20 \text{ sec}$$

7.

Image formed by lens

$$\frac{1}{v} - \frac{1}{u} = \frac{1}{f} \quad ; \quad \frac{1}{v} + \frac{1}{30} = \frac{1}{20}$$

$$v = +60 \text{ cm}$$

If image position does not change even when mirror is removed it means image formed by lens is formed at centre of curvature of spherical mirror.

Radius of curvature of mirror =  $80 - 60 = 20$  cm.

$\Rightarrow$  Focal length of mirror  $f = 10$  cm for virtual image, object is to be kept between focus and pole.

$\Rightarrow$  Maximum distance of object from spherical mirror for which virtual image is formed, is 10 cm.

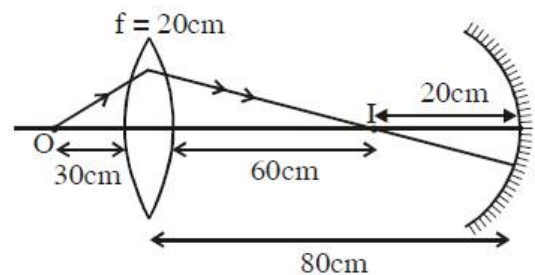

8. Current  $i = \frac{E}{r+R}$

Power generated in R

$$P = i^2 R$$

$$P = \frac{E^2 R}{(r+R)^2}$$

For maximum power  $\frac{dP}{dR} = 0$

$$E^2 \left[ \frac{(r+R)^2 \times 1 - R \times 2(r+R)}{(r+R)^4} \right] = 0$$

$$\Rightarrow r = R$$

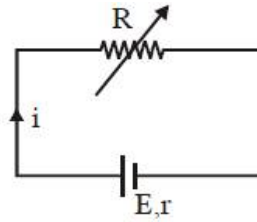

9.  $T = \frac{30 \text{ sec}}{20}$        $\Delta T = \frac{1}{20} \text{ sec,}$   
 $L = 55 \text{ cm}$        $\Delta L = 1 \text{ mm} = 0.1 \text{ cm}$

$$g = \frac{4\pi^2 L}{T^2}$$

percentage error in g is

$$\frac{\Delta g}{g} \times 100 = \left( \frac{\Delta L}{L} + \frac{2\Delta T}{T} \right) 100\%$$

$$= \left( \frac{0.1}{55} + \frac{2 \left( \frac{1}{20} \right)}{\frac{30}{20}} \right) 100\% \approx 6.8\%$$

10.  $v_{\text{rms}} = \sqrt{\frac{3RT}{m}}$        $v_{\text{escape}} = \sqrt{2gR_e}$   
 $v_{\text{rms}} = v_{\text{escape}}$   
 $\frac{3RT}{m} = 2gR_e$   
 $\frac{3 \times 1.38 \times 10^{-23} \times 6.02 \times 10^{26}}{2} \times 10 \times 10^3 = 10^4 \text{ k}$

11. Given initial velocity  $u = 0$  and acceleration is constant

At time t

$$v = 0 + at$$

$$\Rightarrow v = at$$

$$\text{Also } x = 0(t) + \frac{1}{2} at^2$$

$$\Rightarrow x = \frac{1}{2} at^2$$

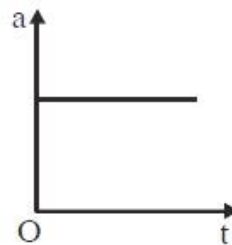

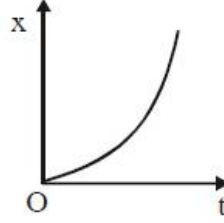
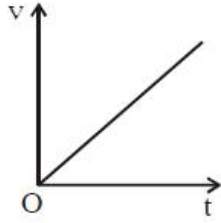

Graph (a), (b) and (d) are correct.

12.  $\vec{E} = (20x + 10)\hat{i}$

$$V_1 - V_2 = -\int_{-5}^1 (20x + 10)dx$$

$$V_1 - V_2 = -(10x^2 + 10x)_{-5}^1$$

$$V_1 - V_2 = 10(25 - 5 - 1 - 1)$$

$$V_1 - V_2 = 180 \text{ V}$$

13. Given:

$$\frac{Y_A}{Y_B} = \frac{7}{4} \quad L_A = 2\text{m} \quad A_A = \pi R^2$$

$$L_B = 1.5 \text{ m} \quad A_B = \pi(2\text{mm})^2$$

$$\frac{F}{A} = Y \left( \frac{\ell}{L} \right)$$

given  $F$  and  $\ell$  are same  $\Rightarrow \frac{AY}{L}$  is same

$$\frac{A_A Y_A}{L_A} = \frac{A_B Y_B}{L_B}$$

$$\Rightarrow \frac{(\pi R^2) \left( \frac{7}{4} Y_B \right)}{2} = \frac{\pi(2\text{mm})^2 \cdot Y_B}{1.5}$$

$$R = 1.74 \text{ mm}$$

14. Applying linear momentum conservation

$$m_1 v_1 \hat{i} + m_2 v_2 \hat{i} = m_1 v_3 \hat{i} + m_2 v_4 \hat{i}$$

$$m_1 v_1 + 0.5 m_1 v_2 = m_1(0.5 v_1) + 0.5 m_1 v_4$$

$$0.5 m_1 v_1 = 0.5 m_1 (v_4 - v_2)$$

$$v_1 = v_4 - v_2$$

15. Mass densities of all nuclei are same so their ratio is 1.

16. Angular impulse = change in angular momentum.

$$\tau \Delta t = \Delta L$$

$$mg \frac{\ell}{2} \times 0.01 = \frac{m \ell^2}{3} \omega$$

$$\omega = \frac{3g \times 0.01}{2\ell} = \frac{3 \times 10 \times 0.01}{2 \times 0.3} = \frac{1}{2} = 0.5 \text{ rad/s}$$

Time taken by rod to hit the ground

$$t = \sqrt{\frac{2h}{g}} = \sqrt{\frac{2 \times 5}{10}} = 1 \text{ sec.}$$

In this time angle rotate by rod

$$\theta = \omega t = 0.5 \times 1 = 0.5 \text{ radian}$$

17. Moment of inertia

$$I = m \left( \frac{d}{2} \right)^2 \times 2 = \frac{md^2}{2}$$

Now by  $\tau = I\alpha$

$$(qE)(d \sin \theta) = \frac{md^2}{2} \cdot \alpha$$

$$\alpha = \left( \frac{2qE}{md} \right) \sin \theta \text{ for small } \theta$$

$$\Rightarrow \alpha = \left( \frac{2qE}{md} \right) \theta$$

$$\Rightarrow \text{Angular frequency } \omega = \sqrt{\frac{2qE}{md}}$$

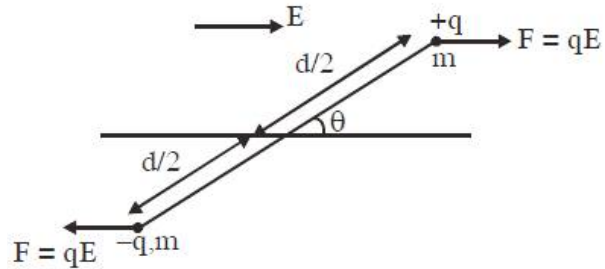

18. If we use that direction of light propagation will be along  $\vec{E} \times \vec{B}$ . Then (A) option is correct.

Magnitude of  $E = CB$

$$E = 3 \times 10^8 \times 1.6 \times 10^{-6} \times \sqrt{5}$$

$$E = 4.8 \times 10^2 \sqrt{5}$$

$\vec{E}$  and  $\vec{B}$  are perpendicular to each other

$$\Rightarrow \vec{E} \cdot \vec{B} = 0$$

$\Rightarrow$  Either direction of  $\vec{E}$  is  $\hat{i} - 2\hat{j}$  or  $-\hat{i} + 2\hat{j}$  from given option

Also wave propagation direction is parallel to  $\vec{E} \times \vec{B}$  which is  $-\hat{k}$

$\Rightarrow \vec{E}$  is along  $(-\hat{i} + 2\hat{j})$

19. At saturation state,  $V_{CE}$  becomes zero

$$\Rightarrow i_c = \frac{10V}{1000 \Omega} = 10 \text{ mA}$$

Now current gain factor  $\beta = \frac{i_c}{i_b}$

$$\Rightarrow i_b = \frac{10 \text{ mA}}{250} = 40 \mu\text{A}$$

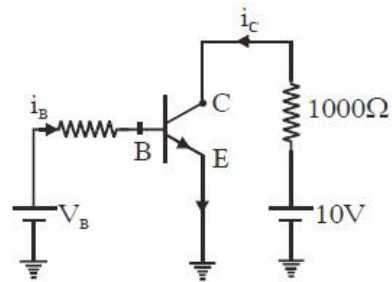

20.  $\frac{1}{2} mV^2 = -q(V_f - V_i)$

$$E = \frac{\lambda}{2\pi\epsilon_0 r}$$

$$\Delta V = \frac{\lambda}{2\pi\epsilon_0} \ln\left(\frac{r_0}{r}\right)$$

$$\frac{1}{2}mv^2 = \frac{-q\lambda}{2\pi\epsilon_0} \ln\left(\frac{r_0}{r}\right)$$

$$v \propto \sqrt{\ln\left(\frac{r}{r_0}\right)}$$

21.  $|\vec{A}_1| = 3, |\vec{A}_2| = 5, \text{ and } |\vec{A}_1 + \vec{A}_2| = 5.$

$$|\vec{A}_1 + \vec{A}_2|^2 = |\vec{A}_1|^2 + |\vec{A}_2|^2 + 2|\vec{A}_1||\vec{A}_2|\cos\theta$$

$$\cos\theta = -\frac{3}{10}$$

$$(2\vec{A}_1 + 3\vec{A}_2) \cdot (3\vec{A}_1 - 2\vec{A}_2)$$

$$= 6|\vec{A}_1|^2 + 9\vec{A}_1 \cdot \vec{A}_2 - 4\vec{A}_1 \cdot \vec{A}_2 - 6|\vec{A}_2|^2$$

$$= -118.5$$

22.

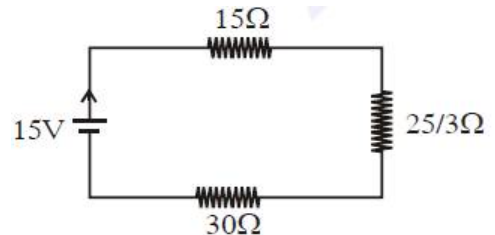
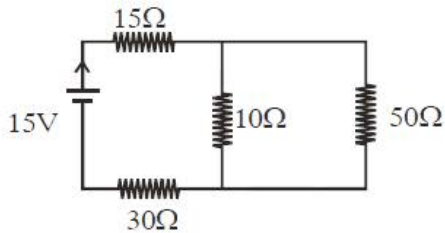
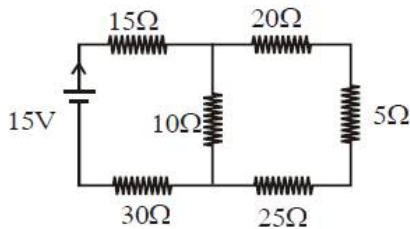

$$R_{eq} = 15 + \frac{25}{3} + 30 = \frac{45 + 25 + 90}{3} = \frac{160}{3}$$

$$I = \frac{E}{R_{eq}} = \frac{15 \times 3}{160} = \frac{9}{32} \text{ amp.}$$

23. Range =  $\sqrt{2Rh_T} + \sqrt{2Rh_R}$

$$50 \times 10^3 = \sqrt{2 \times 6400 \times 10^3 \times h_T} + \sqrt{2 \times 6400 \times 10^3 \times 70}$$

By solving  $h_T = 32 \text{ m.}$



24. Minimum energy required (E) = - (Potential energy of object at surface of earth)

$$= - \left( - \frac{GMm}{R} \right) = \frac{GMm}{R}$$

Now  $M_{\text{earth}} = 64 M_{\text{moon}}$

$$\rho \cdot \frac{4}{3} \pi R_e^3 = 64 \cdot \frac{4}{3} \pi R_m^3 \Rightarrow R_e = 4R_m$$

Now  $\frac{E_{\text{moon}}}{E_{\text{earth}}} = \frac{M_{\text{moon}}}{M_{\text{earth}}} \cdot \frac{R_{\text{earth}}}{R_{\text{moon}}} = \frac{1}{64} \times \frac{4}{1}$

$$\Rightarrow E_{\text{moon}} = \frac{E}{16}$$

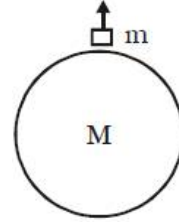

25. Given phase difference =  $\frac{\pi}{4}$  and  $\omega = 100 \text{ rad/s}$

$\Rightarrow$  Reactance (X) = Resistance (R)  
Now by checking option.

Option (A)

$$R = 1000 \Omega \text{ and } X_C = \frac{1}{10^{-6} \times 100} = 10^4 \Omega$$

Option (B)

$$R = 10^3 \Omega \text{ and } X_L = 10 \times 10^{-3} \times 100 = 1 \Omega$$

Option (C)

$$R = 10^3 \Omega \text{ and } X_L = 10^{-3} \times 100 = 10^{-1} \Omega$$

Option (D)

$$R = 10^3 \Omega \text{ and } X_C = \frac{1}{10 \times 10^{-6} \times 100} = 10^3 \Omega$$

- 26.

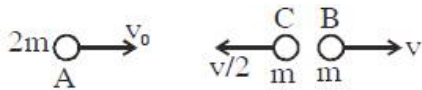

Let mass of B and C is m each. By momentum conservation

$$2mv_0 = mv - \frac{mv}{2}$$

$$v = 4v_0$$

$$P_A = 2mv_0 \quad p_B = 4mv_0 \quad p_C = 2mv_0$$

De-Broglie wavelength  $\lambda = \frac{h}{p}$

$$\lambda_A = \frac{h}{2mv_0}; \lambda_B = \frac{h}{4mv_0}; \lambda_C = \frac{h}{2mv_0}$$

27. Limit of resolution of telescope =  $\frac{1.22 \lambda}{D}$

$$\theta = \frac{1.22 \times 500 \times 10^{-9}}{200 \times 10^{-2}} = 305 \times 10^{-9} \text{ radian}$$

28. Magnetic field at point P

$$\vec{B}_{\text{net}} = \frac{\mu_0 I}{2\pi d} (-\hat{k}) + \frac{\mu_0 I}{2\pi d} (\hat{k}) = 0$$

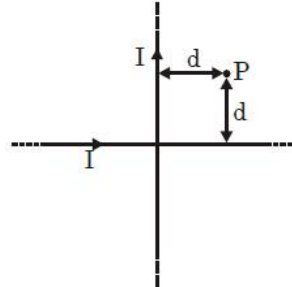

29. isochoric → Process d  
 Isobaric → Process a  
 Adiabatic slope will be more than isothermal so  
 Isothermal → Process b  
 Adiabatic → Process c  
 Order → d a b c

30.

$$x = \frac{M \frac{a}{2} - \frac{M}{4} \times \frac{3a}{4}}{M - \frac{M}{4}}$$

$$= \frac{\frac{a}{2} - \frac{3a}{16} \times \frac{3a}{4}}{\frac{3}{4}} = \frac{\frac{5a}{16}}{\frac{3}{4}} = \frac{5a}{12}$$

$$y = \frac{M \frac{b}{2} - \frac{M}{4} \times \frac{3b}{4}}{M - \frac{M}{4}} = \frac{5b}{12}$$

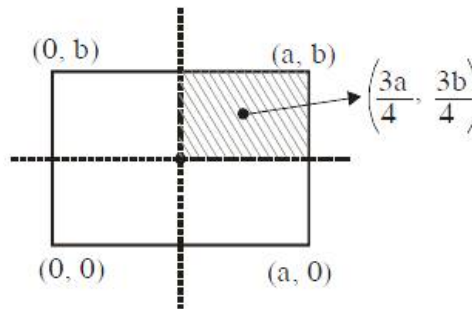

## PART B – CHEMISTRY

31. In case of interstitial compounds there is presence of small atoms (or impurity) in the lattice of metal. So interstitial compounds are hard, high melting point and chemically inert.

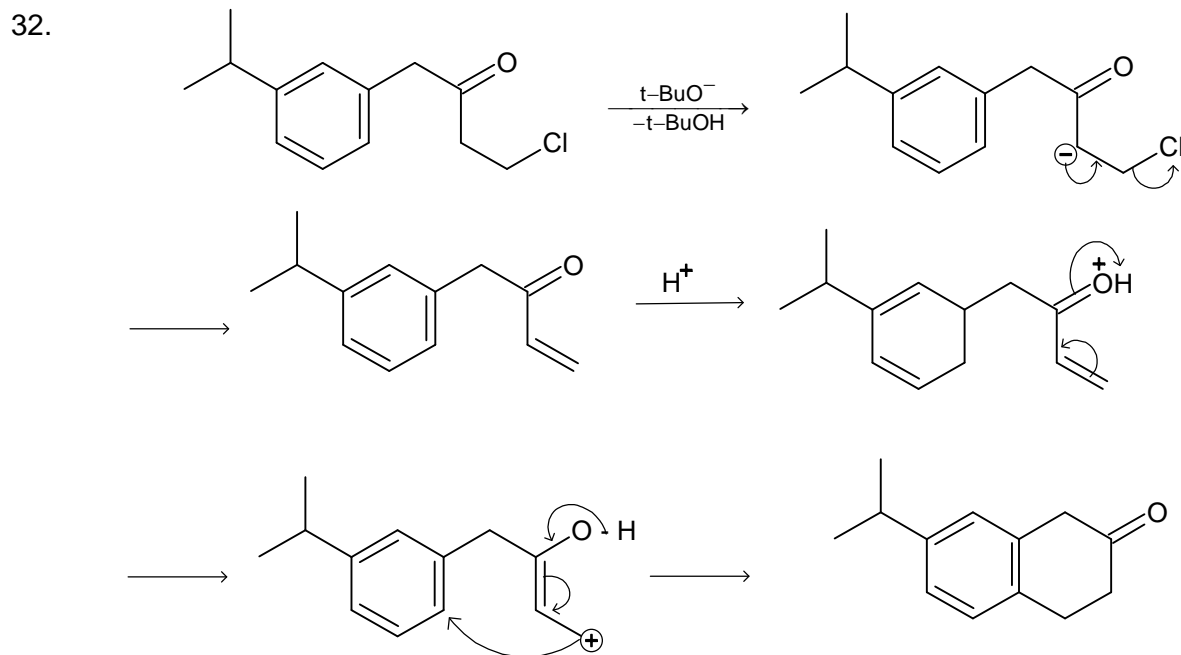

33. Reaction involves free radical chlorination followed by hydrolysis.

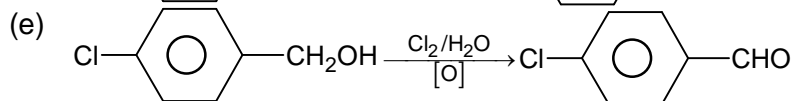
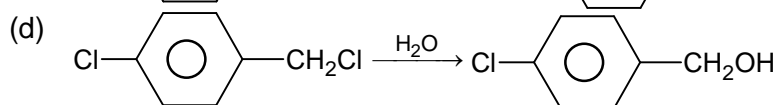
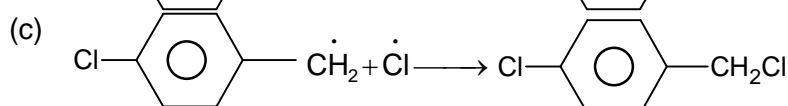
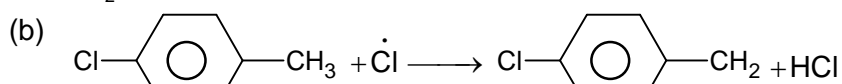
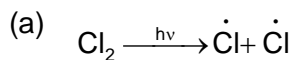

34.

$$\text{K.E} = \frac{1}{2} m u^2 = \frac{1}{2} \frac{m^2 u^2}{m} = \frac{1}{2} \frac{P^2}{m}$$

$$\frac{hc}{\lambda_1} = W_0 + (\text{K.E})_1 = W_0 + \frac{1}{2} \frac{P^2}{m}$$

$$\frac{hc}{\lambda_2} = W_0 + (\text{K.E})_2 = W_0 + \frac{1}{2} \frac{(1.5P)^2}{m}$$

On solving

$$\lambda_2 = \frac{4}{9} \lambda_1$$

Since the K.E is very high is comparison to work function, then we can assume that  
K.E +  $W_0$  = K.E

35.  $[\text{ICl}_4]^- \rightarrow \text{sp}^3\text{d}^2$   
 $[\text{IF}_6]^- \rightarrow \text{sp}^3\text{d}^2$   
 $[\text{ICl}_2]^- \rightarrow \text{sp}^3\text{d}$   
 $[\text{BrF}_2]^- \rightarrow \text{sp}^3\text{d}$

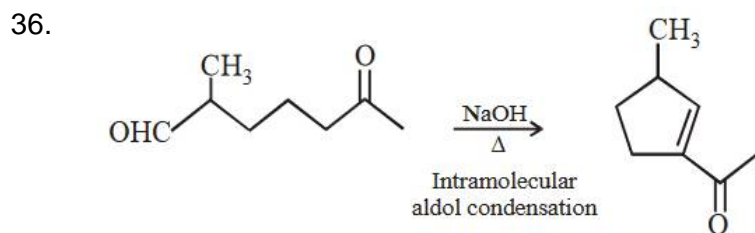

37. Applying steady state of approximation

$$\frac{d}{dt}[\text{B}] = K_1[\text{A}] - K_2[\text{B}]$$

$$0 = K_1[\text{A}] - K_2[\text{B}]$$

$$\frac{K_1}{K_2}[\text{A}] = [\text{B}]$$

38.  $2\text{SO}_2(\text{g}) + \text{O}_2(\text{g}) \longrightarrow 2\text{SO}_3(\text{g})$

$$K_{\text{eq}} = \frac{[\text{SO}_3]^2}{[\text{O}_2][\text{SO}_2]^2}$$

$$= \frac{K_2}{K_1} = \frac{10^{129}}{10^{104}} = 10^{25}$$

- 39.

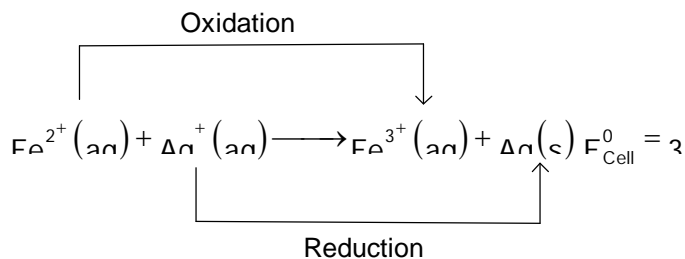

Given:

$$E_{\text{Ag}^+/\text{Ag}}^0 = x \quad \text{----- (1)}$$

$$E_{\text{Fe}^{2+}/\text{Fe}}^0 = y \quad \text{----- (2)}$$

$$E_{\text{Fe}^{3+}/\text{Fe}}^0 = z \quad \text{----- (3)}$$

Using equation:

$$\Delta G^0 = -nFE^0$$

$$\Delta G_1^0 = -Fx$$

$$\Delta G_2^0 = -2Fy$$

$$\Delta G_3^0 = -3Fz$$

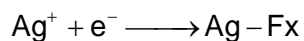
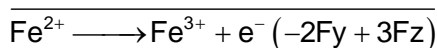
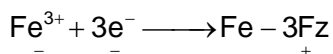
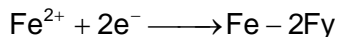

$$\Delta G_{\text{Total}} = -2Fy + 3Fz - Fx = -FE_{\text{Cell}}^0$$

$$E_{\text{Cell}}^0 = x + 2y - 3z$$

40. The % covalent character can be predicted by using Fajan's rule

$$\% \text{ of covalent character} \propto \frac{1}{\text{cationic radius}}$$

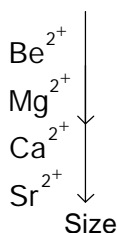

41. The direct monomer of Nylon-6 is caprolactum which polymerises to give Nylon-6 as follows:

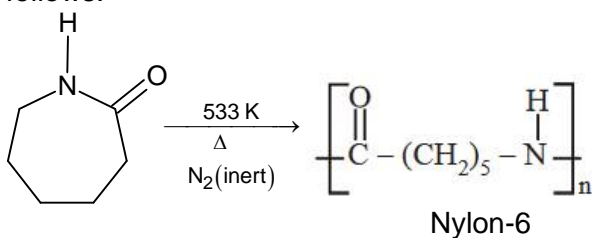

42. The IUPAC name of element having atomic number 119 is "Ununennium". So its symbol is uue.

- 43.

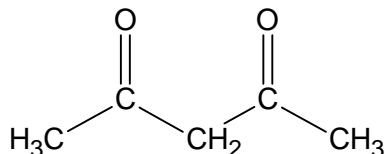

Due to presence of active methylene group and stabilization of enol by intramolecular H bond forming 6 membered ring structure.

44. Mass of fatty acid = 0.027 g  
 Radius of plate = 10 cm  
 Density of fatty acid = 0.9 g/cm<sup>3</sup>  
 Volume of fatty acid =  $\frac{0.027}{0.9} = 0.03 \text{ cm}^3$   
 Area of plate =  $\pi r^2 = 3 \times 10^2 = 300 \text{ cm}^2$   
 Height of fatty acid =  $\frac{\text{Volume}}{\text{Area}} = \frac{0.03}{300} = 10^{-4} \text{ cm} = 10^{-6} \text{ m}$

45. In CH<sub>4</sub>  
 Mole of carbon n<sub>C</sub> = 1  
 Mole of hydrogen = n<sub>H</sub> = 4  
 % of n<sub>C</sub> =  $\frac{n_C}{n_C + n_H} \times 100 = \frac{1}{5} \times 100 = 20\%$

46. The mond's process is used for refining of nickel as per following reaction.

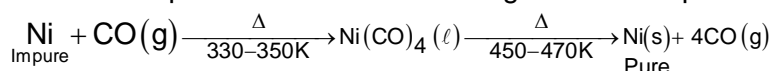

47. In this case antimarkonikov product will be formed as major product because carbocation formed at a double bonded carbon having lesser number of H atom will be unstable due to presence of an electron withdrawing group (CF<sub>3</sub>) attached to it.

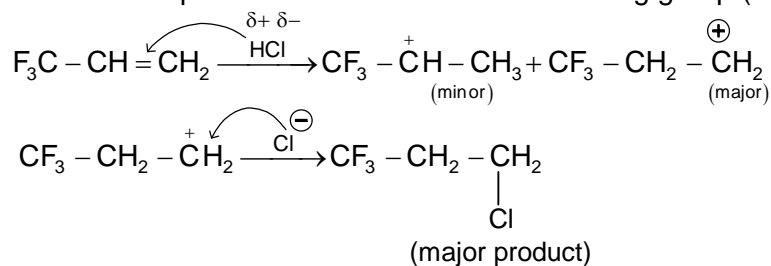

48.  $\Delta U = nC_v m \times \Delta T$   
 $= 5 \times 28 \times 100 = 14 \text{ kJ}$   
 $\Delta PV = nR\Delta T$   
 $= 5 \times 8 \times 100 = 4 \text{ kJ}$

- |  |  |
|--|--|
| <p>49. <math>[\text{Fe}(\text{CN})_6]^{4-}</math><br/> <math>\text{Fe}^{2+} \longrightarrow 3d^6</math><br/> <math>t_{2g}^6 e_g^0</math><br/> <math>\mu = \sqrt{n(n+2)}</math><br/> <math>\mu = 0</math></p> | <p><math>[\text{Fe}(\text{H}_2\text{O})_6]^{2+}</math><br/> <math>\text{Fe}^{2+} \longrightarrow 3d^6</math><br/> <math>t_{2g}^4 e_g^2</math><br/> <math>\mu = \sqrt{n(n+2)} = \sqrt{24} = 4.9 \text{ BM}</math></p> |
|--|--|

50. Barfoed's test → Detecting presence of monosaccharides  
 Fehling's test → For aldehydes  
 Benedict's test → For reducing sugars  
 Seliwanoff's test → Differentiate between aldose and ketose

51.

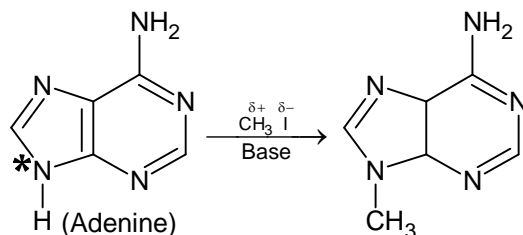

The nitrogen atom marked with \* contain high electron density. It is attached to one H-atom which can be removed by base  $\text{OH}^-$  and the  $\text{CH}_3$  group gets attached there.

52. Polysubstitution is a major drawback of Friedal craft's alkylation. It is so because activating behaviour of benzene ring increases with increase in number of alkyl group on benzene ring.

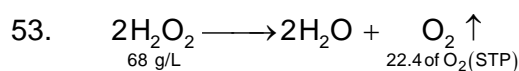

$\frac{68 \text{ g/L}}{2\text{H}_2\text{O}_2} \qquad \qquad \qquad \frac{22.4 \text{ of O}_2(\text{STP})}{\text{O}_2}$

11.2 L of  $\text{O}_2$  is given by 34 g of  $\text{H}_2\text{O}_2$  present in 1 L of  $\text{H}_2\text{O}_2$  solution.

So % strength of  $\text{H}_2\text{O}_2 = \frac{34}{1000} \times 100 = 3.4\text{g} / 100\text{mL} = 3.4\%$

54. From Henry's law

$$P_{\text{gas}} = K_H \cdot X_{\text{gas}}$$

$$P_{\text{gas}} = K_H (1 - X_{\text{H}_2\text{O}})$$

$$P_{\text{gas}} = K_H - K_H X_{\text{H}_2\text{O}}$$

Comparing this equation with straight line equation  $y = mx + c$

55. 
$$\text{O}_2^- - \sigma_{1s}^2 \sigma_{1s}^* \sigma_{2s}^2 \sigma_{2s}^* \sigma_{2p_z}^2 \left[ \pi_{2p_x}^2 = \pi_{2p_y}^2 \right] \sigma_{2p_z}^2$$

$$B.O = \frac{10^{-4}}{2} = 2 \text{ (diamagnetic)}$$

$$\text{NO}^- - \sigma_{1s}^2 \sigma_{1s}^* \sigma_{2s}^2 \sigma_{2s}^* \sigma_{2p_z}^2 \left[ \pi_{2p_x}^2 = \pi_{2p_y}^2 \right] \sigma_{2p_z}^2 \left[ \pi_{2p_x}^1 = \pi_{2p_y}^1 \right]$$

$$B.O = \frac{10^{-6}}{2} = 2 \text{ (paramagnetic)}$$

$$\text{O}_2^- - \sigma_{1s}^2 \sigma_{1s}^* \sigma_{2s}^2 \sigma_{2s}^* \sigma_{2p_z}^2 \left[ \pi_{2p_x}^2 = \pi_{2p_y}^2 \right] \left[ \pi_{2p_x}^2 = \pi_{2p_y}^2 \right]$$

$$B.O = \frac{10^{-8}}{2} = 1 \text{ (diamagnetic)}$$

$$\text{O}_2 - \sigma_{1s}^2 \sigma_{1s}^* \sigma_{2s}^2 \sigma_{2s}^* \sigma_{2p_z}^2 \left[ \pi_{2p_x}^2 = \pi_{2p_y}^2 \right] \left[ \pi_{2p_x}^1 = \pi_{2p_y}^1 \right]$$

$$B.O = \frac{10^{-6}}{2} = 2 \text{ (paramagnetic)}$$

56. The reaction involves carbylamine reaction of 1° amine with  $\text{CHCl}_3/\text{KOH}$  followed by reduction with  $\text{Pd/C}/\text{H}_2$ .

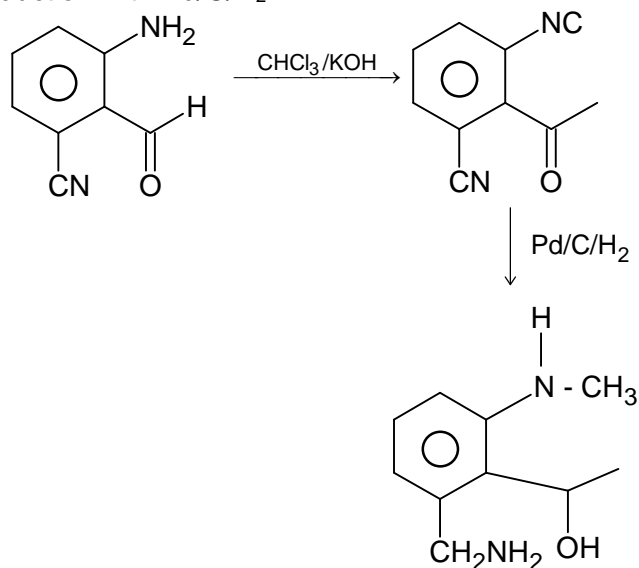

57. Maximum prescribed concentration of copper in drinking water is 3 ppm. Above this concentration water becomes toxic.

58.

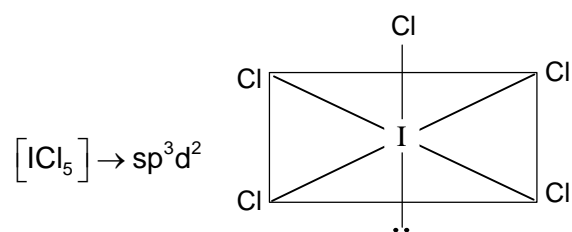
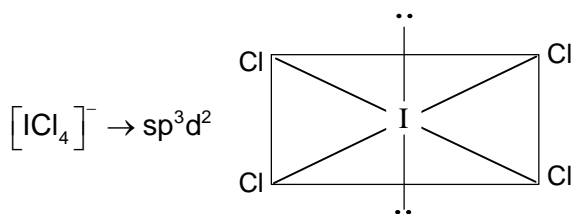

59.  $\text{cis-}[\text{PtCl}_2(\text{NH}_3)_2]$  is used in chemotherapy to inhibit the growth of tumors

60. 
$$\% \text{ packing efficiency} = \frac{\text{Vol. occupied by atom}}{\text{Vol. of unit cell}} \times 100 = \frac{\frac{4}{3}\pi r^3}{a^3} \times 100$$

Let radius of corner atom is  $r$  and radius of central atom is  $2r$

So,  $\sqrt{3}a = 2(2r) + 2r = 6r$

$$a = \frac{6r}{\sqrt{3}} = 2\sqrt{3}r$$

Now



$$\begin{aligned} \% \text{ P.E} &= \frac{\frac{4}{3} \pi r^3 + \frac{4}{3} \pi (2r)^3}{(2\sqrt{3}r)^3} \times 100 \\ &= \frac{\frac{4}{3} \pi (r^3 + 8r^3)}{8 \times 3\sqrt{3} r^3} \times 100 \\ &= \frac{4\pi \times 9r^3}{3 \times 8 \times 3\sqrt{3} r^3} \times 100 = 90.6\% \approx 90\% \end{aligned}$$

### PART C – MATHEMATICS

61. 
$$S(\lambda) = 2 \int_0^\lambda \sqrt{x} \, dx = \frac{4}{3} \lambda^{3/2}$$

$$\frac{S(\lambda)}{S(4)} = \frac{2}{5} \Rightarrow \frac{\lambda^{3/2}}{4^{3/2}} = \frac{2}{5}$$

$$\Rightarrow \lambda = 4 \left( \frac{4}{25} \right)^{1/3}$$

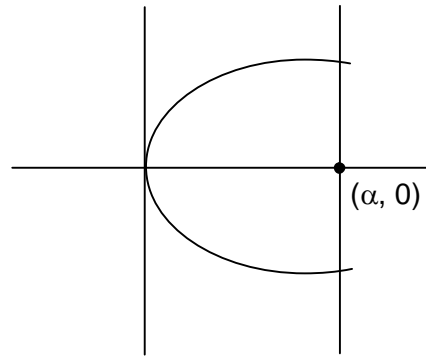

62. Since  $g(x)$  is even with  $f(0) = 0$   
 $f(x)$  is odd function  
 $g(x) = f(x+5)$   
 $g(-x) = f(-x+5)$   
 $g(x) = -f(x-5)$   
 Replace  $x$  by  $x+5$   
 $\Rightarrow f(x) = -g(x+5)$

$$\begin{aligned} \int_0^x f(t) \, dt &= - \int_0^x g(t+5) \, dt \\ &= - \int_5^{x+5} g(t) \, dt \\ &= \int_{x+5}^5 g(t) \, dt \end{aligned}$$

63. Equation of  $L_1$  is  $x + 2y = 5$  and equation of  $L_2$  is  $2x - y = 5$   
 Their point of intersection is  $(3, 1)$   
 $\Rightarrow \frac{k}{h} = \frac{1}{3}$

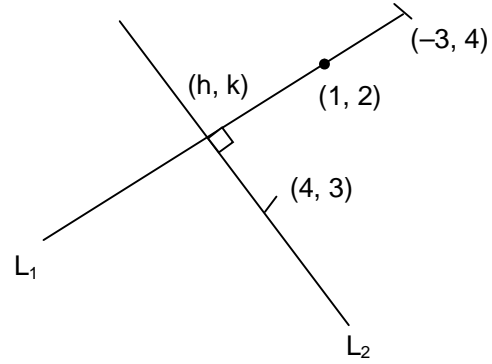

64.  $f_1(x) = \frac{a^x + a^{-x}}{2}$  and  $f_2(x) = \frac{a^x - a^{-x}}{2}$   
 $f_1(x+y) + f_1(x-y)$   
 $= \frac{1}{2}(a^{x+y} + a^{-x-y} + a^{x-y} + a^{-x+y})$   
 $= \frac{1}{2}(a^x(a^y + a^{-y}) + a^{-x}(a^y + a^{-y}))$   
 $= 2 \cdot \left(\frac{a^x + a^{-x}}{2}\right) \left(\frac{a^y + a^{-y}}{2}\right)$   
 $= 2f_1(x)f_1(y)$

65.  $f(x) = \begin{cases} -x-1 & x \in [-1, 0) \\ x & x \in [0, 1) \\ 2x & x \in [1, 2) \\ x+2 & x \in [2, 3) \end{cases}$   
 $f(x)$  is discontinuous at  $x = 0, 1$

66.  $z = \frac{\sqrt{3} + i}{2} = e^{i\pi/6}$   
 $(1 + iz + z^5 + iz^8)^9$   
 $= (1 + e^{i\pi/2}e^{i\pi/6} + e^{i5\pi/6} + e^{i\pi/2}e^{i8\pi/6})^9$   
 $= \left(1 + e^{i2\pi/6} + e^{i5\pi/6} + e^{i\frac{11\pi}{6}}\right)^9$   
 $= \left(\frac{1}{2} + i\frac{\sqrt{3}}{2}\right)^9 = (e^{i\pi/3})^9 = e^{i3\pi} = -1$

67. (A)  $(p \vee q) \rightarrow (p \vee (\sim q))$   
 $= \sim(p \vee q) \vee (p \vee \sim q)$   
 $= (\sim p \wedge \sim q) \vee (p \vee \sim q)$   
 $\neq T$

$$\begin{aligned}
 \text{(B) } & (p \wedge q) \rightarrow p \\
 & = \sim(p \wedge q) \vee p = (\sim p \vee \sim q) \vee p \\
 & = (\sim p \vee p) \vee \sim q \\
 & = T
 \end{aligned}$$

$$\begin{aligned}
 \text{(C) } & \sim p \vee (p \vee q) \\
 & = (\sim p \vee p) \vee q = T
 \end{aligned}$$

$$\begin{aligned}
 \text{(D) } & \sim(p \vee q) \vee (\sim p \vee q) \\
 & = (\sim p \vee \sim q) \vee (\sim p \vee q) \\
 & = \sim p \vee T = T
 \end{aligned}$$

$$\begin{aligned}
 68. \quad & \frac{dy}{dx} = \frac{2y}{x^2} \\
 & \Rightarrow \ln y = -\frac{2}{x} + \ln C
 \end{aligned}$$

Passes through (1, 1)

$$0 = -2 + \ln C$$

$$\Rightarrow \ln y = \frac{-2}{x} + 2$$

$$x \ln |y| = 2(x - 1)$$

$$\begin{aligned}
 69. \quad & f = f(f(f(x))) + (f(x))^2 \\
 & \frac{dy}{dx} = f'(f(f(x)))f'(f(x))f'(x) + 2f(x)f'(x) \\
 & \text{Put } x = 1 \\
 & \frac{dy}{dx} = 27 + 6 = 33
 \end{aligned}$$

$$\begin{aligned}
 70. \quad & \text{Starting with } 5 = 6^3 = 216 \\
 & \text{Starting with } 44 = 6^2 = 36 \\
 & \text{Starting with } 45 = 6^2 = 36 \\
 & \text{Starting with } 43 = 18 \text{ (Not using 0, 1, 2)} \\
 & \text{Starting with } 432 = 4 \\
 & \text{Total} = 310
 \end{aligned}$$

$$\begin{aligned}
 71. \quad & \text{Equation of PQ is } \frac{x-2}{6} = \frac{y+3}{3} = \frac{z-4}{6} \\
 & R(4, y, z) \text{ lies on this} \\
 & \Rightarrow \frac{1}{3} = \frac{y+3}{3} = \frac{z-4}{6} \\
 & \Rightarrow R(4, -2, 6) \\
 & QR = \sqrt{16 + 4 + 36} = 2\sqrt{14}
 \end{aligned}$$

72. For infinitely many solutions

$$\begin{vmatrix} 1 & -2 & k \\ 2 & 1 & 1 \\ 3 & -1 & -k \end{vmatrix} = 0$$

$$\Rightarrow k = \frac{-1}{2}$$

Also consider

$$x - 2y + k = 1 \text{ and } 2x + y + z = 2$$

$$\Rightarrow 2x - 4y - z - 2$$

$$2x + y + z = 2$$

$$\Rightarrow 4x - 3y = 4$$

73.  $AM = \frac{41 + 45 + 54 + 57 + 43 + x}{6} = 48$

$$\Rightarrow x = 48$$

$$\sigma^2 + 48^2 = \frac{1}{6}(41^2 + 45^2 + 54^2 + 57^2 + 43^2 + 48^2)$$

$$\sigma^2 = \frac{14024}{6} - 2304$$

$$= \frac{100}{3}$$

74.  $P_1: x + y + z = 1$

$$P_2: 2x + 3y + 4z = 5$$

Required plane is  $P_1 + \lambda P_2 = 0$

$$\Rightarrow (1 + 2\lambda)x + (1 + 3\lambda)y + (1 + 4\lambda)z = 1 + 5\lambda \quad \dots(i)$$

which is perpendicular to  $x - y + z = 0$

$$\Rightarrow 1 + 2\lambda - (1 + 3\lambda) + 1 + 4\lambda = 0$$

$$\Rightarrow \lambda = \frac{-1}{3}$$

$$(i) \Rightarrow x - z + 2 = 0$$

$$\vec{r} \cdot (\hat{i} - \hat{k}) + 2 = 0$$

75. Given  $2b = a + c$

Let  $A = \theta, B = \pi - 3\theta, C = 2\theta$

$$2\sin B = \sin A + \sin C$$

$$2\sin 3\theta = \sin \theta + \sin 2\theta$$

$$2(3 - 4\sin^2 \theta) = (1 + 2\cos \theta)$$

$$\Rightarrow 8\cos^2 \theta - 2\cos \theta - 3 = 0$$

$$\Rightarrow \cos \theta = \frac{3}{4}$$

$$\sin A : \sin B : \sin C$$

$$\Rightarrow 1:4-3\sin^2\theta:2\cos\theta$$

$$\Rightarrow 1:\frac{5}{4}:\frac{6}{4}$$

$$\Rightarrow 4:5:6$$

76.  $be = 5\sqrt{3}$

$$b^2e^2 = 75$$

$$(b-a)(b+a) = 75 \Rightarrow b+a = 15$$

$$\Rightarrow b = 10, a = 5$$

$$LR = \frac{2a^2}{b} = 5$$

77.  $1 - \frac{1}{2^n} > \frac{9}{10}$

$$\Rightarrow \frac{1}{10} > \frac{1}{2^n}$$

$$\Rightarrow 2^n > 10$$

$$\Rightarrow n = 4$$

78. Let equation of hyperbola be  $\frac{x^2}{a^2} - \frac{y^2}{b^2} = 1$

passes through (4, 6)

$$\Rightarrow \frac{16}{a^2} - \frac{36}{b^2} = 1 \quad (i)$$

$$\text{Also } e^2 = 1 + \frac{b^2}{a^2} \Rightarrow b^2 = 3a^2 \quad (ii)$$

From (i) and (ii)

$$a^2 = 4, b^2 = 12$$

$$\text{Equation } \frac{x^2}{4} - \frac{y^2}{12} = 1$$

$$\text{Tangent at (4, 6) is } x - \frac{y}{2} = 1$$

Or

$$2x - y = 2$$

79.  $D = 4(1+3m)^2 - 4(1+m^2)(1+8m)$

$$= 4(1+9m^2+6m-1-8m-m^2-8m^3)$$

$$= -8m(4m^2-4m+1)$$

$$= -8m(2m-1)^2 < 0$$

$\therefore$  Infinitely many values of  $m$ .

$$\begin{aligned}
80. \quad S &= \sum_{k=1}^{20} \frac{k}{2^k} \\
S &= \frac{1}{2} + \frac{2}{2^2} + \frac{3}{2^3} + \dots + \frac{20}{2^{20}} \\
S \frac{1}{2} &= \frac{1}{2^2} + \frac{2}{2^3} + \dots + \frac{20}{2^{21}} \\
\frac{1}{2}S &= \frac{1}{2} + \frac{1}{2^2} + \frac{1}{2^3} + \dots + \frac{1}{2^{20}} - \frac{20}{2^{21}} \\
&= \frac{1 \left( 1 - \frac{1}{2^{20}} \right)}{\frac{1}{2}} - \frac{20}{2^{21}} \\
&= 1 - \frac{21}{2^{21}} \\
s &= 2 - \frac{11}{2^{19}}
\end{aligned}$$

$$\begin{aligned}
81. \quad \vec{a} \times \vec{b} &= \begin{vmatrix} \hat{i} & \hat{j} & \hat{k} \\ 3 & 2 & x \\ 1 & -1 & 1 \end{vmatrix} \\
&= (2+x)\hat{i} - (3-x)\hat{j} - 5\hat{k} \\
|\vec{a} \times \vec{b}| &= \sqrt{2(x^2 - x + 19)} \\
&= \sqrt{2} \sqrt{(x - 1/2)^2 + 19^{-1/4}} \geq \frac{5\sqrt{3}}{\sqrt{2}}
\end{aligned}$$

$$\begin{aligned}
82. \quad \text{Slope of OP} &= \frac{1}{\sqrt{3}} \\
\text{Equation of PQ is} \\
y - 1 &= -\sqrt{3}(x - \sqrt{3}) \\
\Rightarrow y + \sqrt{3}x &= 4 \\
\Rightarrow Q \left( \frac{4}{\sqrt{3}}, 0 \right) \\
\text{Area} &= \frac{2}{\sqrt{3}}
\end{aligned}$$

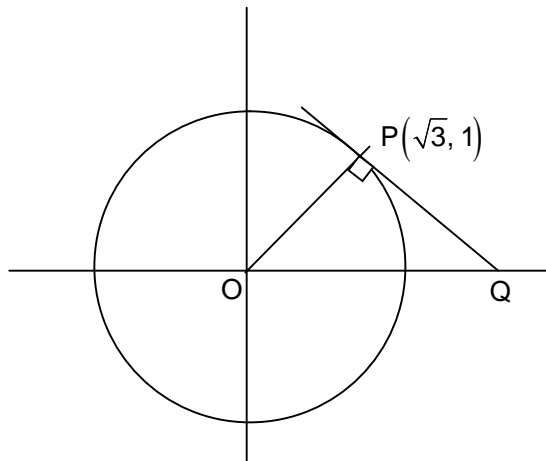

83.  $x^2 + 4x = 5$   
 $\Rightarrow x = -5, x = 1$   
 $\Rightarrow P(1, 2)$   
Tangent at P is  $y = x + 1$   
 $\left(\frac{3}{4}, \frac{7}{4}\right)$  lies on this.

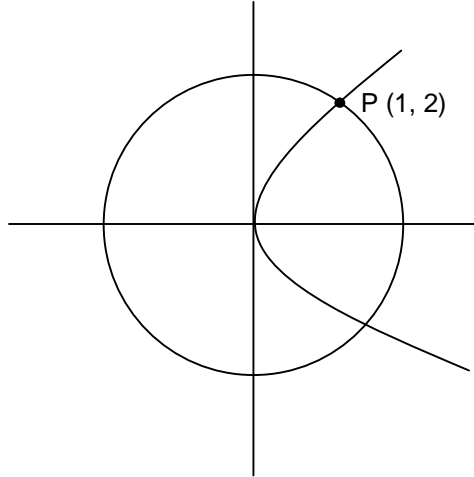

84.  $h = 2(3 \cos \theta) = 6 \cos \theta, r = 3 \sin \theta$   
 $V = \pi r^2 h$   
 $= \pi(4 \sin^2 \theta)(6 \cos \theta)$   
 $= 54 \pi \sin^2 \theta \cos \theta$   
 $\frac{dv}{d\theta} = 0 \Rightarrow 2 \sin \theta \cos \theta - \sin^3 \theta = 0$   
 $\Rightarrow 2 \sin \theta - 3 \sin^3 \theta = 0$   
 $\Rightarrow \sin \theta = \pm \sqrt{\frac{2}{3}}$   
 $\cos \theta = \sqrt{\frac{1}{3}}$   
 $h = \frac{6}{\sqrt{3}}$

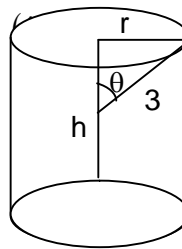

85.  $\begin{vmatrix} 1 & 1 & 1 \\ 2 & b & c \\ 4 & b^2 & c^2 \end{vmatrix}$   
 $C_2 \rightarrow C_2 - C_1, C_3 \rightarrow C_3 - C_1$   
 $\Rightarrow \begin{vmatrix} 1 & 0 & 0 \\ 2 & b-2 & c-2 \\ 4 & b^2-4 & c^2-4 \end{vmatrix}$   
 $= (b-2)(c-2) \begin{vmatrix} 1 & 1 \\ b+2 & c+2 \end{vmatrix}$   
 $|A| = (b-2)(c-2)(c-b)$   
 $2, b, c$  are in AP  $\Rightarrow 2, 2+d, 2+2d$   
 $\Rightarrow |A| = (d)(2d)(d) = 2d^3 \in [2, 16]$   
 $\Rightarrow d^3 \in [1, 8]$

$$\Rightarrow 2d \in [2, 4]$$

$$\Rightarrow 2 + 2d \in [4, 6]$$

86.  $1^\infty$  Form

$$k = \lim_{x \rightarrow 0} \left( \frac{f(3+x) - f(2x) - f(3)(f(2))}{x(1+f(2-x) - f(2))} \right)$$

$$= \lim_{x \rightarrow 0} \frac{f'(3+x) + f'(2-x)}{(1+f(2-x) - f(2)) - xf'(2-x)}$$

$$= 0$$

$$\Rightarrow e^k = 1$$

87.  $I = \int \frac{dx}{x^3(1+x^6)^{2/3}}$

$$= \int \frac{dx}{x^7 \left(1 + \frac{1}{x^6}\right)^{2/3}}$$

Put  $1+x^{-6} = t \Rightarrow \frac{dx}{x^7} = \frac{-dt}{6}$

$$I = \frac{1}{6} \int \frac{-dt}{t^{2/3}} = \frac{-1}{2} \left[1 + \frac{1}{x^6}\right]^{1/3} + C$$

$$= \frac{-1}{2} \frac{(1+x^6)^{1/3}}{x^2} = x f(x) (1+x^6)^{1/3} + C$$

$$\Rightarrow f(x) = \frac{-1}{2x^3}$$

88.  $\frac{h}{y} = \frac{20}{x}, \frac{h}{x-y} = \frac{80}{x}$

$$\frac{h}{20} = \frac{y}{x}, \frac{h}{80} = \frac{x-y}{x}$$

$$\frac{h}{20} + \frac{h}{80} = 1$$

$$h \left( \frac{100}{1600} \right) = 1$$

$$h = 16$$

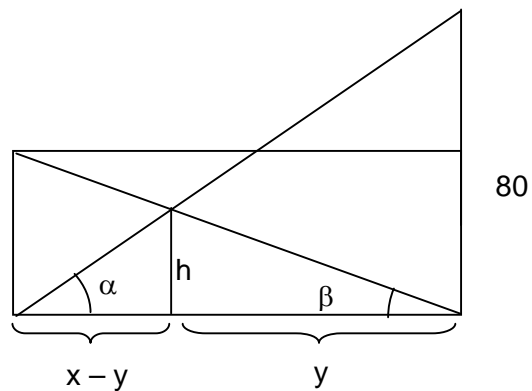

89.  ${}^6C_3 x - \frac{3}{2}(1+\log x) \cdot x^{1/4} = 200$

$$x^{1/4} - \frac{3}{2}(1+\log x) = 10$$

$$\Rightarrow \frac{1}{4} - \frac{3}{2}(1+\log_{10} x) \cdot \log_{10} x = 1$$



$$\Rightarrow 6t^2 + 5t + 4 = 0, t = \log_{10} x$$

$$D < 0$$

So no real solution

All options are incorrect

90.  $b^2 = ac$

Also roots of  $ax^2 + 2bx + c = 0$  are equal

$$\Rightarrow x = \frac{-b}{a}, \text{ common root}$$

$$\Rightarrow d\left(\frac{-b}{a}\right)^2 + 2e\left(\frac{-b}{a}\right) + f = 0$$

$$db^2 - 2aeb + fa^2 = 0, b^2 = ac$$

$$\Rightarrow dac - 2eab + fa^2 = 0$$

$$\Rightarrow dc - 7eb + fa = 0$$

Dividing by  $ac$

$$\Rightarrow \frac{d}{a} - \frac{2e}{b} + \frac{f}{c} = 0$$

$$\Rightarrow \frac{d}{a} + \frac{f}{c} = 2 \cdot \frac{e}{b}$$