

## PHYSICS

1. In a screw gauge, 5 complete rotations of the screw cause it to move a linear distance of 0.25 cm. There are 100 circular scale divisions. The thickness of a wire measured by this screw gauge gives a reading of 4 main scale divisions and 30 circular scale divisions. Assuming negligible zero error, the thickness of the wire is:
- (1) 0.3150 cm                      (2) 0.2150 cm  
 (3) 0.4300 cm                      (4) 0.0430 cm

Ans. (2)

2. A body of mass  $m$  is moving in a circular orbit of radius  $R$  about a planet of mass  $M$ . At some instant, it splits into two equal masses. The first mass moves in a circular orbit of radius  $\frac{R}{2}$ , and the other mass, in a circular orbit of radius  $\frac{3R}{2}$ . The difference between the final and initial total energies is :

- (1)  $+\frac{GMm}{6R}$                       (2)  $\frac{GMm}{2R}$   
 (3)  $-\frac{GMm}{2R}$                       (4)  $-\frac{GMm}{6R}$

Ans. (4)

3.

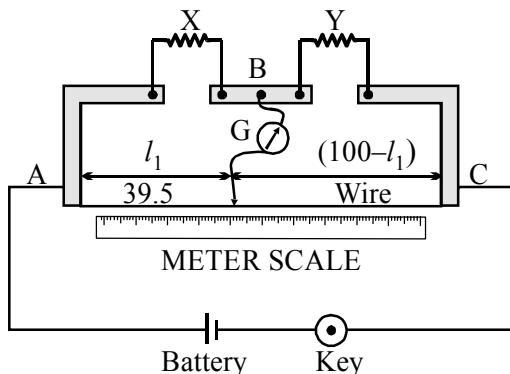

In a meter bridge, as shown in the figure, it is given that resistance  $Y = 12.5 \Omega$  and that the balance is obtained at a distance 39.5 cm from end A (by Jockey J). After interchanging the resistances X and Y, a new balance point is found at a distance  $l_2$  from end A. What are the values of X and  $l_2$ ?

- (1) 19.15  $\Omega$  and 60.5 cm  
 (2) 8.16  $\Omega$  and 60.5 cm  
 (3) 8.16  $\Omega$  and 39.5 cm  
 (4) 19.15  $\Omega$  and 39.5 cm

Ans. (2)

4. The number of amplitude modulated broadcast stations that can be accommodated in a 300 kHz band width for the highest modulating frequency 15 kHz will be :

- (1) 20                      (2) 10                      (3) 8                      (4) 15

Ans. (1)

5. A force of 40 N acts on a point B at the end of an L-shaped object, as shown in the figure. The angle  $\theta$  that will produce maximum moment of the force about point A is given by :

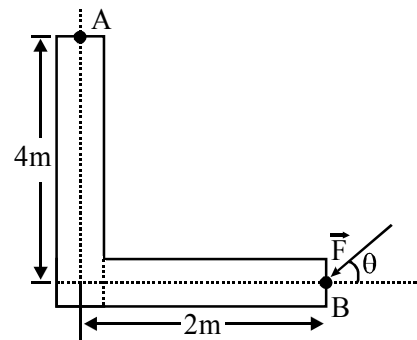

- (1)  $\tan \theta = \frac{1}{2}$                       (2)  $\tan \theta = 4$

- (3)  $\tan \theta = 2$                       (4)  $\tan \theta = \frac{1}{4}$

Ans. (1)

6. The velocity - time graphs of a car and a scooter are shown in the figure. (i) The difference between the distance travelled by the car and the scooter in 15 s and (ii) the time at which the car will catch up with the scooter are, respectively.

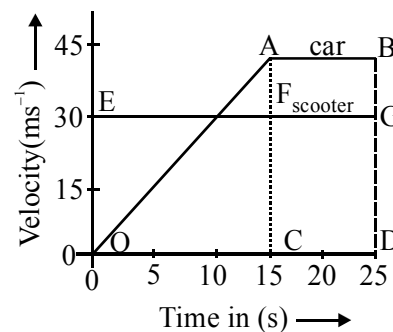

- (1) 112.5 m and 15 s                      (2) 337.5 m and 25 s  
 (3) 225.5 m and 10 s                      (4) 112.5 m and 22.5 s

Ans. (4)

7. A body of mass  $M$  and charge  $q$  is connected to a spring of spring constant  $k$ . It is oscillating along  $x$ -direction about its equilibrium position, taken to be at  $x=0$ , with an amplitude  $A$ . An electric field  $E$  is applied along the  $x$ -direction. Which of the following statements is correct ?

(1) The total energy of the system is

$$\frac{1}{2}m\omega^2 A^2 - \frac{1}{2} \frac{q^2 E^2}{k}$$

(2) The new equilibrium position is at a distance

$$\frac{2qE}{k} \text{ from } x = 0.$$

(3) The new equilibrium position is at a distance

$$\frac{qE}{2k} \text{ from } x = 0.$$

(4) The total energy of the system is

$$\frac{1}{2}m\omega^2 A^2 + \frac{1}{2} \frac{q^2 E^2}{k}.$$

Ans. (Bonus)

8. An automobile, travelling at 40 km/h, can be stopped at a distance of 40 m by applying brakes. If the same automobile is travelling at 80 km/h, the minimum stopping distance, in meters, is (assume no skidding)

- (1) 100 m                      (2) 75 m  
(3) 160 m                      (4) 150 m

Ans. (3)

9. A charge  $Q$  is placed at a distance  $a/2$  above the centre of the square surface of edge  $a$  as shown in the figure

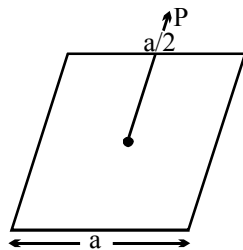

The electric flux through the square surface is :

- (1)  $\frac{Q}{3\epsilon_0}$                       (2)  $\frac{Q}{6\epsilon_0}$   
(3)  $\frac{Q}{\epsilon_0}$                         (4)  $\frac{Q}{2\epsilon_0}$

Ans. (2)

10.

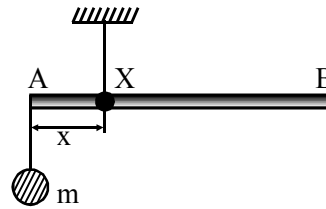

A uniform rod  $AB$  is suspended from a point  $X$ , at a variable distance  $x$  from  $A$ , as shown. To make the rod horizontal, a mass  $m$  is suspended from its end  $A$ . A set of  $(m, x)$  values is recorded. The appropriate variables that give a straight line, when plotted, are :

- (1)  $m, \frac{1}{x^2}$                       (2)  $m, x^2$   
(3)  $m, x$                         (4)  $m, \frac{1}{x}$

Ans. (4)

11. In the given circuit all resistances are of value  $R$  ohm each. The equivalent resistance between  $A$  and  $B$  is :

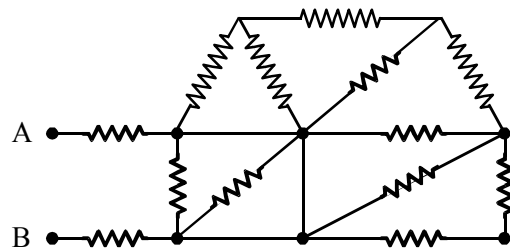

- (1)  $2R$                       (2)  $\frac{5R}{2}$                       (3)  $3R$                       (4)  $\frac{5R}{3}$

Ans. (1)

12. A solution containing active cobalt  ${}^{60}_{27}\text{Co}$  having activity of  $0.8 \mu\text{Ci}$  and decay constant  $\lambda$  is injected in an animal's body. If  $1 \text{ cm}^3$  of blood is drawn from the animal's body after 10 hrs of injection, the activity found was 300 decays per minute. What is the volume of blood that is flowing in the body ? ( $1 \text{ Ci} = 3.7 \times 10^{10}$  decays per second and at  $t = 10 \text{ hrs } e^{-\lambda t} = 0.84$ ).

- (1) 4 litres                      (2) 7 liters  
(3) 5 liters                      (4) 6 liters

Ans. (2)

13. One mole of an ideal monoatomic gas is compressed isothermally in a rigid vessel to double its pressure at room temperature, 27°C. The work done on the gas will be :

- (1) 300 R                      (2) 300 R ln 2  
 (3) 300 R ln 6                (4) 300 R ln 7

Ans. (2)

14. A monochromatic beam of light has a frequency

$$\nu = \frac{3}{2\pi} \times 10^{12} \text{ Hz}$$

and is propagating along the direction  $\frac{\hat{i} + \hat{j}}{\sqrt{2}}$ . It is polarized along the  $\hat{k}$

direction. The acceptable form for the magnetic field is :

(1)  $\frac{E_0}{C} \frac{(\hat{i} + \hat{j} + \hat{k})}{\sqrt{3}} \cos \left[ 10^4 \frac{(\hat{i} + \hat{j})}{\sqrt{2}} \cdot \vec{r} + (3 \times 10^{12})t \right]$

(2)  $\frac{E_0}{C} \frac{(\hat{i} - \hat{j})}{\sqrt{2}} \cos \left[ 10^4 \frac{(\hat{i} + \hat{j})}{\sqrt{2}} \cdot \vec{r} - (3 \times 10^{12})t \right]$

(3)  $\frac{E_0}{C} \frac{(\hat{i} - \hat{j})}{\sqrt{2}} \cos \left[ 10^4 \frac{(\hat{i} - \hat{j})}{\sqrt{2}} \cdot \vec{r} - (3 \times 10^{12})t \right]$

(4)  $\frac{E_0}{C} \hat{k} \cos \left[ 10^4 \frac{(\hat{i} + \hat{j})}{\sqrt{2}} \cdot \vec{r} + (3 \times 10^{12})t \right]$

Ans. (2)

15. Take the mean distance of the moon and the sun from the earth to be  $0.4 \times 10^6$  km and  $150 \times 10^6$  km respectively. Their masses are  $8 \times 10^{22}$  kg and  $2 \times 10^{30}$  kg respectively. The radius of the earth is 6400 km. Let  $\Delta F_1$  be the difference in the forces exerted by the moon at the nearest and farthest points on the earth and  $\Delta F_2$  be the difference in the force exerted by the sun at the nearest and farthest points on the earth. Then, the number

closest to  $\frac{\Delta F_1}{\Delta F_2}$  is :-

- (1) 2                                (2) 0.6  
 (3) 6                                (4)  $10^{-2}$

Ans. (1)

16. The energy required to remove the electron from a singly ionized Helium atom is 2.2 times the energy required to remove an electron from Helium atom. The total energy required to ionize the Helium atom completely is :

- (1) 34 eV                        (2) 79 eV  
 (3) 20 eV                        (4) 109 eV

Ans. (4)

17. An ideal capacitor of capacitance 0.2  $\mu\text{F}$  is charged to a potential difference of 10 V. The charging battery is then disconnected. The capacitor is then connected to an ideal inductor of self inductance 0.5 mH. The current at a time when the potential difference across the capacitor is 5 V, is :

- (1) 0.34 A    (2) 0.17 A    (3) 0.25 A    (4) 0.15 A

Ans. (2)

18. A carnot's engine works as a refrigerator between 250 K and 300 K. It receives 500 cal heat from the reservoir at the lower temperature. The amount of work done in each cycle to operate the refrigerator is :

- (1) 2520 J                        (2) 772 J  
 (3) 2100 J                        (4) 420 J

Ans. (1)

19. A particle is oscillating on the X-axis with an amplitude 2 cm about the point  $x_0 = 10$  cm, with a frequency  $\omega$ . A concave mirror of focal length 5 cm is placed at the origin (see figure).

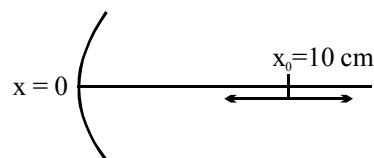

Identify the correct statements.

- (a) The image executes periodic motion  
 (b) The image executes non-periodic motion  
 (c) The turning points of the image are asymmetric w.r.t. the image of the point at  $x = 10$  cm.  
 (d) The distance between the turning points of the

oscillation of the image is  $\frac{100}{21}$  cm.

- (1) b, d                                (2) b, c  
 (3) a, c, d                            (4) a, d

Ans. (3)

20. The equivalent capacitance between A and B in the circuit given below, is :

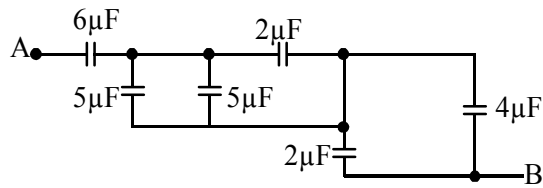

- (1)  $5.4 \mu\text{F}$                       (2)  $4.9 \mu\text{F}$   
 (3)  $3.6 \mu\text{F}$                       (4)  $2.4 \mu\text{F}$

Ans. (4)

21. A Helmholtz coil has a pair of loops, each with  $N$  turns and radius  $R$ . They are placed coaxially at distance  $R$  and the same current  $I$  flows through the loops in the same direction. The magnitude of magnetic field at  $P$ , midway between the centres  $A$  and  $C$ , is given by [Refer to figure given below]:

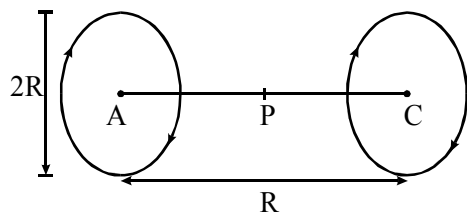

- (1)  $\frac{4N\mu_0 I}{5^{1/2}R}$   
 (2)  $\frac{4N\mu_0 I}{5^{3/2}R}$   
 (3)  $\frac{8N\mu_0 I}{5^{3/2}R}$   
 (4)  $\frac{8N\mu_0 I}{5^{1/2}R}$

Ans. (3)

22. The relative error in the determination of the surface area of a sphere is  $\alpha$ . Then the relative error in the determination of its volume is :

- (1)  $\frac{3}{2}\alpha$                       (2)  $\alpha$   
 (3)  $\frac{5}{2}\alpha$                       (4)  $\frac{2}{3}\alpha$

Ans. (1)

23. The B–H curve for a ferromagnet is shown in the figure. The ferromagnet is placed inside a long solenoid with 1000 turns/cm. The current that should be passed in the solenoid to demagnetise the ferromagnet completely is :-

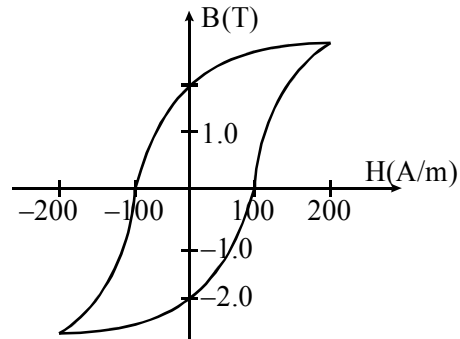

- (1) 1 mA                      (2) 20  $\mu\text{A}$   
 (3) 2 mA                      (4) 40  $\mu\text{A}$

Ans. (1)

24. Light of wavelength 550 nm falls normally on a slit of width  $22.0 \times 10^{-5}$  cm. The angular position of the second minima from the central maximum will be (in radians) :

- (1)  $\frac{\pi}{8}$                       (2)  $\frac{\pi}{12}$   
 (3)  $\frac{\pi}{6}$                       (4)  $\frac{\pi}{4}$

Ans. (3)

25. Two electrons are moving with non-relativistic speeds perpendicular to each other. If corresponding de Broglie wavelengths are  $\lambda_1$  and  $\lambda_2$ , their de Broglie wavelength in the frame of reference attached to their centre of mass is :

- (1)  $\lambda_{\text{CM}} = \frac{2\lambda_1\lambda_2}{\sqrt{\lambda_1^2 + \lambda_2^2}}$                       (2)  $\lambda_{\text{CM}} = \lambda_1 = \lambda_2$   
 (3)  $\lambda_{\text{CM}} = \left(\frac{\lambda_1 + \lambda_2}{2}\right)$                       (4)  $\frac{1}{\lambda_{\text{CM}}} = \frac{1}{\lambda_1} + \frac{1}{\lambda_2}$

Ans. (1)

26. A given object takes  $n$  times more time to slide down a  $45^\circ$  rough inclined plane as it takes to slide down a perfectly smooth  $45^\circ$  incline. The coefficient of kinetic friction between the object and the incline is :

(1)  $\sqrt{1 - \frac{1}{n^2}}$

(2)  $1 - \frac{1}{n^2}$

(3)  $\frac{1}{2 - n^2}$

(4)  $\sqrt{1 - n^2}$

Ans. (2)

27. In a common emitter configuration with suitable bias, it is given that  $R_L$  is the load resistance and  $R_{BE}$  is small signal dynamic resistance (input side). Then, voltage gain, current gain and power gain are given, respectively, by :

$\beta$  is current gain,  $I_B$ ,  $I_C$  and  $I_E$  are respectively base, collector and emitter currents.

(1)  $\beta \frac{R_L}{R_{BE}}, \frac{\Delta I_E}{\Delta I_B}, \beta^2 \frac{R_L}{R_{BE}}$

(2)  $\beta \frac{R_L}{R_{BE}}, \frac{\Delta I_C}{\Delta I_B}, \beta^2 \frac{R_L}{R_{BE}}$

(3)  $\beta^2 \frac{R_L}{R_{BE}}, \frac{\Delta I_C}{\Delta I_E}, \beta^2 \frac{R_L}{R_{BE}}$

(4)  $\beta^2 \frac{R_L}{R_{BE}}, \frac{\Delta I_C}{\Delta I_B}, \beta \frac{R_L}{R_{BE}}$

Ans. (2)

28. A tuning fork vibrates with frequency 256 Hz and gives one beat per second with the third normal mode of vibration of an open pipe. What is the length of the pipe ? (Speed of sound in air is  $340 \text{ ms}^{-1}$ )

(1) 190 cm                      (2) 180 cm

(3) 200 cm                      (4) 220 cm

Ans. (3)

29. A thin uniform tube is bent into a circle of radius  $r$  in the vertical plane. Equal volumes of two immiscible liquids, whose densities are  $\rho_1$  and  $\rho_2$  ( $\rho_1 > \rho_2$ ), fill half the circle. The angle  $\theta$  between the radius vector passing through the common interface and the vertical is :

(1)  $\theta = \tan^{-1} \frac{\pi}{2} \left( \frac{\rho_1 + \rho_2}{\rho_1 - \rho_2} \right)$

(2)  $\theta = \tan^{-1} \frac{\pi}{2} \left( \frac{\rho_2}{\rho_1} \right)$

(3)  $\theta = \tan^{-1} \pi \left( \frac{\rho_1}{\rho_2} \right)$

(4)  $\theta = \tan^{-1} \left[ \frac{\pi}{2} \left( \frac{\rho_1 - \rho_2}{\rho_1 + \rho_2} \right) \right]$

Ans. (4)

30. A planoconvex lens becomes an optical system of 28 cm focal length when its plane surface is silvered and illuminated from left to right as shown in Fig-A.

If the same lens is instead silvered on the curved surface and illuminated from other side as in Fig-B. it acts like an optical system of focal length 10 cm. The refractive index of the material of lens is :

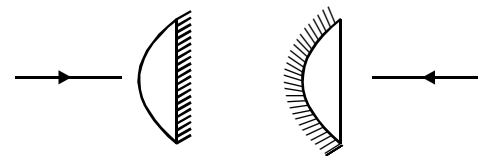

(1) 1.75

(2) 1.51

(3) 1.55

(4) 1.50

Ans. (3)

## CHEMISTRY

1. In the molecular orbital diagram for the molecular ion,  $N_2^+$ , the number of electrons in the  $\sigma_{2p}$  molecular orbital is :-

(1) 3      (2) 1      (3) 0      (4) 2

Ans. (2)

2. An ideal gas undergoes a cyclic process as shown in figure.

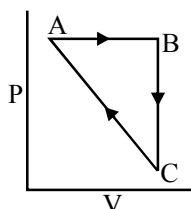

$$\Delta U_{BC} = -5 \text{ kJ mol}^{-1}, q_{AB} = 2 \text{ kJ mol}^{-1}$$

$$W_{AB} = -5 \text{ kJ mol}^{-1}, W_{CA} = 3 \text{ kJ mol}^{-1}$$

Heat absorbed by the system during process CA is :-

(1) 18 kJ mol<sup>-1</sup>      (2) +5 kJ mol<sup>-1</sup>  
 (3) -5 kJ mol<sup>-1</sup>      (4) -18 kJ mol<sup>-1</sup>

Ans. (2)

3. The reagent(s) required for the following conversion are :-

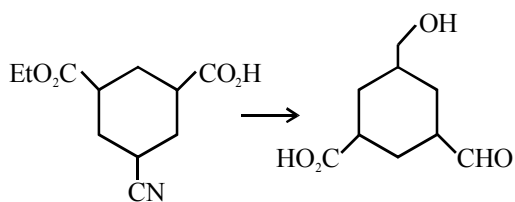

(1) (i)  $LiAlH_4$       (ii)  $H_3O^+$   
 (2) (i)  $B_2H_6$       (ii) DIBAL-H  
     (iii)  $H_3O^+$   
 (3) (i)  $B_2H_6$       (ii)  $SnCl_2/HCl$   
     (iii)  $H_3O^+$   
 (4) (i)  $NaBH_4$       (ii) Raney  $Ni/H_2$   
     (iii)  $H_3O^+$

Ans. (3)

4. The increasing order of nitration of the following compound is :-

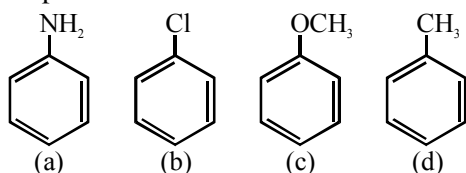

(1) (b) < (a) < (c) < (d)    (2) (b) < (a) < (d) < (c)  
 (3) (a) < (b) < (c) < (d)    (4) (a) < (b) < (d) < (c)

Ans. (4)

5. The decreasing order of bond angles in  $BF_3$ ,  $NH_3$ ,  $PF_3$  and  $I_3^-$  is :-

(1)  $I_3^- > BF_3 > NH_3 > PF_3$   
 (2)  $BF_3 > NH_3 > PF_3 > I_3^-$   
 (3)  $I_3^- > NH_3 > PF_3 > BF_3$   
 (4)  $BF_3 > I_3^- > PF_3 > NH_3$

Ans. (1)

6.  $H-\overset{(I)}{N} \cdots \overset{(II)}{N}-N$

In hydrogen azide (above) the bond orders of bonds (I) and (II) are :-

(1) >2      <2  
 (2) <2      <2  
 (3) <2      >2  
 (4) >2      >2

Ans. (3)

7. The main reduction product of the following compound with  $NaBH_4$  in methanol is :-

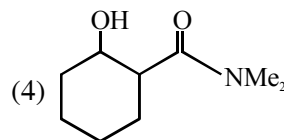
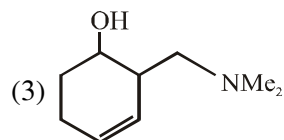
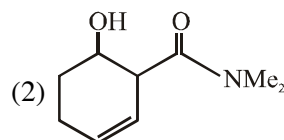
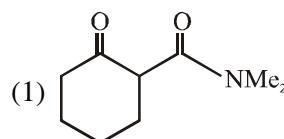
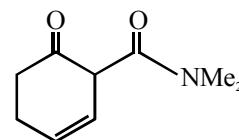

Ans. (2)

8. Identify the pair in which the geometry of the species is T-shape and square-pyramidal, respectively :-

- (1)  $\text{IO}_3^-$  and  $\text{IO}_2\text{F}_2^-$       (2)  $\text{XeOF}_2$  and  $\text{XeOF}_4$   
 (3)  $\text{ICl}_2^-$  and  $\text{ICl}_5$       (4)  $\text{ClF}_3$  and  $\text{IO}_4^-$

Ans. (2)

9. The major product of the following reaction is :

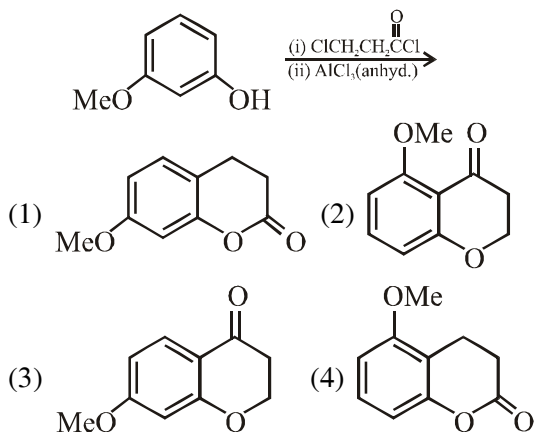

Ans. (1)

10. The IUPAC name of the following compound is :

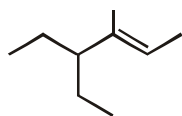

- (1) 4-methyl-3-ethylhex-4-ene  
 (2) 4,4-diethyl-3-methylbut-2-ene  
 (3) 3-ethyl-4-methylhex-4-ene  
 (4) 4-ethyl-3-methylhex-2-ene

Ans. (4)

11. For which of the following reactions,  $\Delta H$  is equal to  $\Delta U$  ?

- (1)  $2\text{NO}_2(\text{g}) \rightarrow \text{N}_2\text{O}_4(\text{g})$   
 (2)  $2\text{HI}(\text{g}) \rightarrow \text{H}_2(\text{g}) + \text{I}_2(\text{g})$   
 (3)  $2\text{SO}_2(\text{g}) + \text{O}_2(\text{g}) \rightarrow 2\text{SO}_3(\text{g})$   
 (4)  $\text{N}_2(\text{g}) + 3\text{H}_2(\text{g}) \rightarrow 2\text{NH}_3(\text{g})$

Ans. (2)

12. The correct combination is

- (1)  $[\text{Ni}(\text{CN})_4]^{2-}$  – tetrahedral;  
 $[\text{Ni}(\text{CO})_4]$  – paramagnetic  
 (2)  $[\text{NiCl}_4]^{2-}$  – paramagnetic;  
 $[\text{Ni}(\text{CO})_4]$  – tetrahedral  
 (3)  $[\text{NiCl}_4]^{2-}$  – diamagnetic;  
 $[\text{Ni}(\text{CO})_4]$  – square-planar  
 (4)  $[\text{NiCl}_4]^{2-}$  – square-planar;  
 $[\text{Ni}(\text{CN})_4]^{2-}$  – paramagnetic

Ans. (2)

13. For  $\text{Na}^+$ ,  $\text{Mg}^{2+}$ ,  $\text{F}^-$  and  $\text{O}^{2-}$ ; the correct order of increasing ionic radii is :

- (1)  $\text{Mg}^{2+} < \text{Na}^+ < \text{F}^- < \text{O}^{2-}$   
 (2)  $\text{O}^{2-} < \text{F}^- < \text{Na}^+ < \text{Mg}^{2+}$   
 (3)  $\text{Na}^+ < \text{Mg}^{2+} < \text{F}^- < \text{O}^{2-}$   
 (4)  $\text{Mg}^{2+} < \text{O}^{2-} < \text{Na}^+ < \text{F}^-$

Ans. (1)

14. Xenon hexafluoride on partial hydrolysis produces compounds 'X' and 'Y' Compounds 'X' and 'Y' and the oxidation state of Xe are respectively :

- (1)  $\text{XeO}_2\text{F}_2(+6)$  and  $\text{XeO}_2(+4)$   
 (2)  $\text{XeOF}_4(+6)$  and  $\text{XeO}_2\text{F}_2(+6)$   
 (3)  $\text{XeOF}_4(+6)$  and  $\text{XeO}_3(+6)$   
 (4)  $\text{XeO}_2(+4)$  and  $\text{XeO}_3(+6)$

Ans. (2)

15.  $\text{N}_2\text{O}_5$  decomposes to  $\text{NO}_2$  and  $\text{O}_2$  and follows first order kinetics. After 50 minutes, the pressure inside the vessel increases from 50 mmHg to 87.5 mmHg. The pressure of the gaseous mixture after 100 minute at constant temperature will be:

- (1) 116.25 mmHg  
 (2) 175.0 mmHg  
 (3) 106.25 mmHg  
 (4) 136.25 mmHg

Ans. (3)

16. Ejection of the photoelectron from metal in the photoelectric effect experiment can be stopped by applying 0.5 V when the radiation of 250 nm is used. The work function of the metal is :

- (1) 5 eV      (2) 4 eV  
 (3) 5.5 eV      (4) 4.5 eV

Ans. (4)

17. A white sodium salt dissolves readily in water to give a solution which is neutral to litmus. When silver nitrate solution is added to the aforementioned solution, a white precipitate is obtained which does not dissolve in dil. nitric acid. The anion is :

- (1)  $\text{S}^{2-}$       (2)  $\text{SO}_4^{2-}$   
 (3)  $\text{CO}_3^{2-}$       (4)  $\text{Cl}^-$

Ans. (4)

18. The copolymer formed by addition polymerization of styrene and acrylonitrile in the presence of peroxide is :

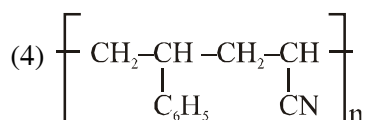
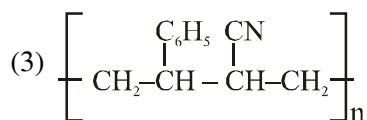
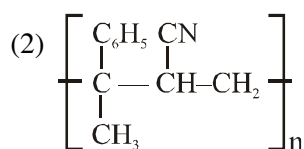
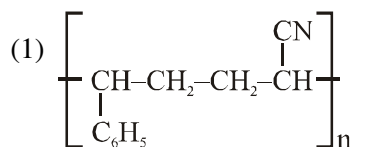

Ans. (4)

19. Which of the following is the correct structure of Adenosine ?

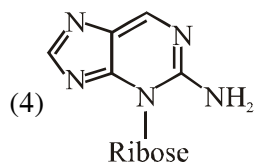
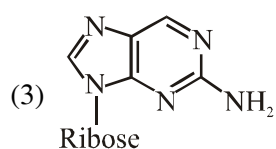
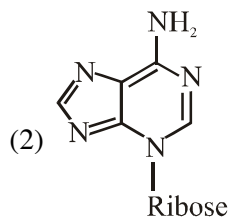
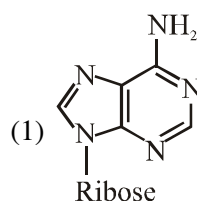

Ans. (1)

20. In which of the following reactions, an increase in the volume of the container will favour the formation of products ?

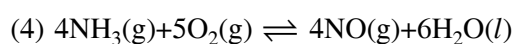
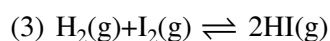
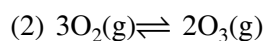
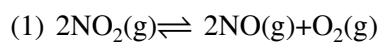

Ans. (1)

21. The correct match between items of List-I and List-II is :

	List-I		List-II
A	Coloured impurity	P	Steam distillation
B	Mixture of o-nitrophenol and p-nitrophenol	Q	Fractional distillation
C	Crude Naphtha	R	Charcoal treatment
D	Mixture of glycerol and sugars	S	Distillation under reduced pressure

(1) (A)-(R), (B)-(S), (C)-(P), (D)-(Q)

(2) (A)-(R), (B)-(P), (C)-(Q), (D)-(S)

(3) (A)-(P), (B)-(S), (C)-(R), (D)-(Q)

(4) (A)-(R), (B)-(P), (C)-(S), (D)-(Q)

Ans. (4)

22. The minimum volume of water required to dissolve 0.1 g lead (II) chloride to get a saturated solution ( $K_{sp}$  of  $\text{PbCl}_2 = 3.2 \times 10^{-8}$ ; atomic mass of Pb = 207 u) is :

(1) 0.36 L (2) 0.18 L (3) 17.98 L (4) 1.798 L

Ans. (2)

23. Which of the following will not exist in zwitter ionic form at pH = 7 ?

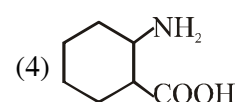
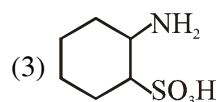
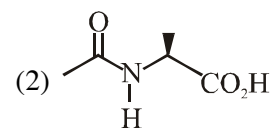
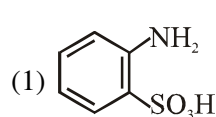

Ans. (2)



24. Which of the following will most readily give the dehydrohalogenation product ?

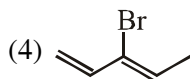
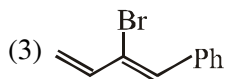
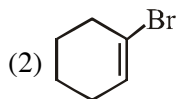
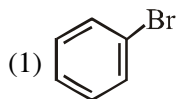

Ans. (3)

25. A sample of  $\text{NaClO}_3$  is converted by heat to  $\text{NaCl}$  with a loss of 0.16 g of oxygen. The residue is dissolved in water and precipitated as  $\text{AgCl}$ . The mass of  $\text{AgCl}$  (in g) obtained will be :

(Given : Molar mass of  $\text{AgCl} = 143.5 \text{ g mol}^{-1}$ )

(1) 0.54 (2) 0.35

(3) 0.48 (4) 0.41

Ans. (3)

26. Which of the following statements about colloids is **False** ?

(1) When excess of electrolyte is added to colloidal solution, colloidal particle will be precipitated.

(2) Freezing point of colloidal solution is lower than true solution at same concentration of a solute.

(3) When silver nitrate solution is added to potassium iodide solution, a negatively charged colloidal solution is formed.

(4) Colloidal particles can pass through ordinary filter paper.

Ans. (2)

27. In graphite and diamond, the percentage of p-characters of the hybrid orbitals in hybridisation are respectively :

(1) 33 and 75 (2) 50 and 75

(3) 33 and 25 (4) 67 and 75

Ans. (4)

28. Which of the following arrangements shows the schematic alignment of magnetic moments of antiferromagnetic substance ?



Ans. (4)

29. When an electric current is passed through acidified water, 112 mL of hydrogen gas at N.T.P. was collected at the cathode in 965 seconds. The current passed, in ampere, is :

(1) 2.0

(2) 1.0

(3) 0.1

(4) 0.5

Ans. (2)

30. Which of the following is a lewis acid ?

(1)  $\text{NaH}$

(2)  $\text{NF}_3$

(3)  $\text{PH}_3$

(4)  $\text{B}(\text{CH}_3)_3$

Ans. (4)

## MATHEMATICS

1. The value of the integral

$$\int_{-\frac{\pi}{2}}^{\frac{\pi}{2}} \sin^4 x \left( 1 + \log \left( \frac{2 + \sin x}{2 - \sin x} \right) \right) dx \text{ is :}$$

(1)  $\frac{3}{8}\pi$  (2) 0

(3)  $\frac{3}{16}\pi$  (4)  $\frac{3}{4}$

**Ans. (1)**

2. If  $(P \wedge \sim q) \wedge (p \wedge r) \rightarrow \sim p \vee q$  is false, then the truth values of p,q and r are respectively

(1) T,T,T (2) F,F,F

(3) T,F,T (4) F,T,F

**Ans. (3)**

3. In a triangle ABC, coordinates of A are (1,2) and the equations of the medians through B and C are respectively,  $x+y = 5$  and  $x = 4$ . Then area of  $\Delta ABC$  (in sq. units) is:

(1) 12 (2) 9 (3) 4 (4) 5

**Ans. (2)**

4. If  $\tan A$  and  $\tan B$  are the roots of the quadratic equation,  $3x^2 - 10x - 25 = 0$ , then the value of  $3 \sin^2(A+B) - 10 \sin(A+B) \cdot \cos(A+B) - 25 \cos^2(A+B)$  is :

(1) 10 (2) -10

(3) 25 (4) -25

**Ans. (4)**

5. An aeroplane flying at a constant speed, parallel to the horizontal ground,  $\sqrt{3}$  km above it, is observed at an elevation of  $60^\circ$  from a point on the ground. If, after five seconds, its elevation from the same point, is  $30^\circ$ , then the speed (in km/hr) of the aeroplane, is :

(1) 750 (2) 1440 (3) 1500 (4) 720

**Ans. (2)**

6. Let A be a matrix such that  $A \cdot \begin{bmatrix} 1 & 2 \\ 0 & 3 \end{bmatrix}$  is a scalar matrix and  $|3A| = 108$ . Then  $A^2$  equals :

(1)  $\begin{bmatrix} 36 & -32 \\ 0 & 4 \end{bmatrix}$  (2)  $\begin{bmatrix} 4 & 0 \\ -32 & 36 \end{bmatrix}$

(3)  $\begin{bmatrix} 4 & -32 \\ 0 & 36 \end{bmatrix}$  (4)  $\begin{bmatrix} 36 & 0 \\ -32 & 4 \end{bmatrix}$

**Ans. (1)**

7. A box 'A' contains 2 white, 3 red and 2 black balls. Another box 'B' contains 4 white, 2 red and 3 black balls. If two balls are drawn at random, without replacement, from a randomly selected box and one ball turns out to be white while the other ball turns out to be red, then the probability that both balls are drawn from box 'B' is :

(1)  $\frac{7}{16}$  (2)  $\frac{7}{8}$  (3)  $\frac{9}{16}$  (4)  $\frac{9}{32}$

**Ans. (1)**

8. If  $\beta$  is one of the angles between the normals to the ellipse,  $x^2 + 3y^2 = 9$  at the points  $(3 \cos \theta, \sqrt{3} \sin \theta)$  and

$(-3 \sin \theta, \sqrt{3} \cos \theta)$ ;  $\theta \in \left( 0, \frac{\pi}{2} \right)$ ; then  $\frac{2 \cot \beta}{\sin 2\theta}$  is

equal to

(1)  $\frac{1}{\sqrt{3}}$  (2)  $\frac{2}{\sqrt{3}}$  (3)  $\sqrt{2}$  (4)  $\frac{\sqrt{3}}{4}$

**Ans. (2)**

9. If a right circular cone, having maximum volume, is inscribed in a sphere of radius 3cm, then the curved surface area (in  $\text{cm}^2$ ) of this cone is :

(1)  $6\sqrt{3}\pi$  (2)  $6\sqrt{2}\pi$

(3)  $8\sqrt{2}\pi$  (4)  $8\sqrt{3}\pi$

**Ans. (4)**

10. If  $\vec{a}, \vec{b}$ , and  $\vec{c}$  are unit vectors such that  $\vec{a} + 2\vec{b} + 2\vec{c} = \vec{0}$ , then  $|\vec{a} \times \vec{c}|$  is equal to :

- (1)  $\frac{1}{4}$       (2)  $\frac{\sqrt{15}}{16}$       (3)  $\frac{15}{16}$       (4)  $\frac{\sqrt{15}}{4}$

Ans. (4)

11. If the tangents drawn to the hyperbola  $4y^2 = x^2 + 1$  intersect the co-ordinate axes at the distinct points A and B, then the locus of the mid point of AB is :

- (1)  $4x^2 - y^2 - 16x^2y^2 = 0$   
 (2)  $4x^2 - y^2 + 16x^2y^2 = 0$   
 (3)  $x^2 - 4y^2 + 16x^2y^2 = 0$   
 (4)  $x^2 - 4y^2 - 16x^2y^2 = 0$

Ans. (4)

12. Consider the following two binary relations on the set  $A = \{a, b, c\}$ :

$R_1 = \{(c, a), (b, b), (a, c), (c, c), (b, c), (a, a)\}$  and  
 $R_2 = \{(a, b), (b, a), (c, c), (c, a), (a, a), (b, b), (a, c)\}$ . Then

- (1)  $R_1$  is not symmetric but it is transitive.  
 (2) both  $R_1$  and  $R_2$  are transitive  
 (3)  $R_2$  is symmetric but it is not transitive  
 (4) both  $R_1$  and  $R_2$  are not symmetric

Ans. (3)

13. A variable plane passes through a fixed point (3, 2, 1) and meets x, y and z axes at A, B and C respectively. A plane is drawn parallel to yz-plane through A, a second plane is drawn parallel to zx-plane through B a third plane is drawn parallel to xy-plane through C. Then the locus of the point of intersection of these three planes, is :

- (1)  $\frac{1}{x} + \frac{1}{y} + \frac{1}{z} = \frac{11}{6}$       (2)  $\frac{x}{3} + \frac{y}{2} + \frac{z}{1} = 1$   
 (3)  $\frac{3}{x} + \frac{2}{y} + \frac{1}{z} = 1$       (4)  $x + y + z = 6$

Ans. (3)

14. Let  $y = y(x)$  be the solution of the differential equation  $\frac{dy}{dx} + 2y = f(x)$ , where  $f(x)$

$= \begin{cases} 1, & x \in [0, 1] \\ 0, & \text{otherwise} \end{cases}$  If  $y(0) = 0$ , then  $y\left(\frac{3}{2}\right)$  is :

- (1)  $\frac{e^2 - 1}{2e^3}$       (2)  $\frac{e^2 - 1}{e^3}$       (3)  $\frac{e^2 + 1}{2e^4}$       (4)  $\frac{1}{2e}$

Ans. (1)

15. If  $\lambda \in \mathbb{R}$  is such that the sum of the cubes of the roots of the equation,  $x^2 + (2 - \lambda)x + (10 - \lambda) = 0$  is minimum, then the magnitude of the difference of the roots of this equation is :

- (1)  $4\sqrt{2}$       (2) 20      (3)  $2\sqrt{7}$       (4)  $2\sqrt{5}$

Ans. (4)

16. If  $f(x) = \frac{\begin{vmatrix} \cos x & x & 1 \\ 2 \sin x & x^2 & 2x \\ \tan x & x & 1 \end{vmatrix}}{\tan x}$ , then  $\lim_{x \rightarrow 0} \frac{f'(x)}{x}$

- (1) exists and is equal to 0  
 (2) exists and is equal to -2  
 (3) exists and is equal to 2  
 (4) does not exist

Ans. (2)

17. The set of all  $\alpha \in \mathbb{R}$ , for which  $w = \frac{1 + (1 - 8\alpha)z}{1 - z}$  is a purely imaginary number, for all  $z \in \mathbb{C}$  satisfying  $|z| = 1$  and  $\text{Re } z \neq 1$ , is :

- (1) an empty set      (2) equal to  $\mathbb{R}$   
 (3)  $\{0\}$       (4)  $\left\{0, \frac{1}{4}, -\frac{1}{4}\right\}$

Ans. (3)

18. If b is the first term of an infinite G.P. whose sum is five, then b lies in the interval :

- (1)  $(-\infty, -10]$       (2)  $(-10, 0)$   
 (3)  $(0, 10)$       (4)  $[10, \infty)$

Ans. (3)

19. An angle between the plane,  $x + y + z = 5$  and the line of intersection of the planes,  $3x + 4y + z - 1 = 0$  and  $5x + 8y + 2z + 14 = 0$ , is

- (1)  $\sin^{-1}\left(\frac{3}{\sqrt{17}}\right)$       (2)  $\cos^{-1}\left(\frac{\sqrt{3}}{\sqrt{17}}\right)$   
 (3)  $\sin^{-1}\left(\frac{\sqrt{3}}{\sqrt{17}}\right)$       (4)  $\cos^{-1}\left(\frac{3}{\sqrt{17}}\right)$

Ans. (3)

20. A circle passes through the points (2,3) and (4,5). If its centre lies on the line,  $y-4x+3=0$ , then its radius is equal to

- (1) 1      (2) 2      (3)  $\sqrt{5}$       (4)  $\sqrt{2}$

Ans. (2)

21. n-digit numbers are formed using only three digits 2,5 and 7. The smallest value of n for which 900 such distinct numbers can be formed, is

- (1) 9      (2) 6      (3) 8      (4) 7

Ans. (4)

22. Let S be the set of all real values of k for which the system of linear equations

$$x+y+z=2$$

$$2x+y-z=3$$

$$3x+2y+kz=4$$

has a unique solution. Then S is

- (1) an empty set      (2) equal to R  
 (3) equal to {0}      (4) equal to  $R-\{0\}$

Ans. (4)

23. The area (in sq. units) of the region

$$\{x \in \mathbb{R} : x \geq 0, y \geq 0, y \geq x-2 \text{ and } y \leq \sqrt{x}\}, \text{ is}$$

- (1)  $\frac{10}{3}$       (2)  $\frac{13}{3}$       (3)  $\frac{5}{3}$       (4)  $\frac{8}{3}$

Ans. (1)

24. Let  $S = \{\lambda, \mu\} \in \mathbb{R} \times \mathbb{R} : f(t) = (|\lambda|) e^{|\mu|t} \cdot \sin(2|t|), t \in \mathbb{R}$ , is a differentiable function}. Then S is a subset of :

- (1)  $[0, \infty) \times \mathbb{R}$       (2)  $\mathbb{R} \times (-\infty, 0)$   
 (3)  $\mathbb{R} \times [0, \infty)$       (4)  $(-\infty, 0) \times \mathbb{R}$

Ans. (3)

25. If  $f\left(\frac{x-4}{x+2}\right) = 2x + 1, (x \in \mathbb{R} - \{-1, -2\})$ , then

$\int f(x)dx$  is equal to :(where C is a constant of integration)

- (1)  $12 \log_e |1-x| - 3x + c$   
 (2)  $-12 \log_e |1-x| - 3x + c$   
 (3)  $-12 \log_e |1-x| + 3x + c$   
 (4)  $12 \log_e |1-x| + 3x + c$

Ans. (2)

26. If  $x^2 + y^2 + \sin y = 4$ , then the value of  $\frac{d^2y}{dx^2}$  at the

point (-2,0) is

- (1) -34      (2) -32      (3) -2      (4) 4

Ans. (1)

27. Two parabolas with a common vertex and with axes along x-axis and y-axis, respectively, intersect each other in the first quadrant. If the length of the latus rectum of each parabola is 3, then the equation of the common tangent to the two parabolas is

- (1)  $4(x+y) + 3 = 0$       (2)  $8(2x+y) + 3 = 0$   
 (3)  $3(x+y) + 4 = 0$       (4)  $x + 2y + 3 = 0$

Ans. (1)

28. The mean of a set of 30 observations is 75. If each observation is multiplied by a non-zero number  $\lambda$  and then each of them is decreased by 25, their mean remains the same. Then  $\lambda$  is equal to

- (1)  $\frac{2}{3}$       (2)  $\frac{10}{3}$       (3)  $\frac{1}{3}$       (4)  $\frac{4}{3}$

Ans. (4)

29. If  $x_1, x_2, \dots, x_n$  and  $\frac{1}{h_1}, \frac{1}{h_2}, \dots, \frac{1}{h_n}$  are two A.P.s

such that  $x_3 = h_2 = 8$  and  $x_8 = h_7 = 20$ , then  $x_5 \cdot h_{10}$  equals :

- (1) 2560      (2) 2650      (3) 3200      (4) 1600

Ans. (1)

30. If n is the degree of the polynomial,

$$\left[ \frac{2}{\sqrt{5x^3+1} - \sqrt{5x^3-1}} \right]^8 +$$

$$\left[ \frac{2}{\sqrt{5x^3+1} + \sqrt{5x^3-1}} \right]^8 \text{ and } m \text{ is the coefficient}$$

of  $x^n$  in it, then the ordered pair (n,m) is equal to:

- (1) (24,  $(10)^8$ )      (2) (12,  $(20)^4$ )  
 (3) (12,  $8(10)^4$ )      (4) (8,  $5(10)^4$ )

Ans. (2)